

BALMUDA

The GreenFan

Electric Fan (for home use)

EGF-1600 Series

Instruction Manual

Warranty Included

Important

Thank you for purchasing The GreenFan.

Please be sure to read this manual,

especially “Safety Precautions” on pages 3-6 before using the product.

Also be sure to take note of content marked with a  on individual pages.

This manual also includes the warranty.

Fill in the spaces for information such as date

and place of purchase, and keep this manual for future reference.



Important

Thank you for purchasing The GreenFan.

Please be sure to read this manual, especially “Safety Precautions” (P. 3–6), before using the product.

Also be sure to take note of content marked with a [] on individual pages.

This manual also includes the warranty.

Fill in the spaces for information such as the date and place of purchase, and keep this manual in a safe place for future references.

Table of Contents



Safety Precautions		
Safety Precautions	3	
Special Cautions	4	
Warning	5	
Caution	6	
Before Using		
Package Contents	7	
Assembly of the Head Unit	8	
Assembly	9	
Using in the Short Size	10	
How to Use		
Operating Instructions	11	
Manual Angle Adjustment	12	
Automatic Oscillation Angle Setting	13	
Using the Remote Control	15	
Replacing the Batteries	16	
Precautions on Using the Remote Control	16	
Using the AC Adapter	17	
Maintenance	18	
Using the Battery & Dock (Sold Separately)		
Installation	19	
Storing the Product	21	
Product Specifications	22	
Troubleshooting		
Troubleshooting	23	
Warranty and After-Purchase Service	25	
Handling of Personal Information	25	
Disposal of waste batteries and electrical and electronic equipment	26	
Customer Service	26	
Warranty	27	

Safety Precautions

Please read the safety precautions and use the product correctly. The cautions herein are intended to help you use the product safely and avoid injury and property damage.

When using the separately sold Battery & Dock, be sure to read and follow the included instruction manual.

The following classifications indicate hazards or damage that could result from improper use.

 Warning	Indicates possibility of death or serious injury.
 Caution	Indicates possibility of minor injury or damage to buildings, property, etc.

The following symbols indicate precautions that must be followed.

 Indicates actions that must not be done.	 Indicates actions that must be done.
--	--

- In case of emergencies such as an earthquake or fire, immediately unplug and stop use of the product.
- This product is intended for home use only. Please do not use for any other purposes.

Special Cautions

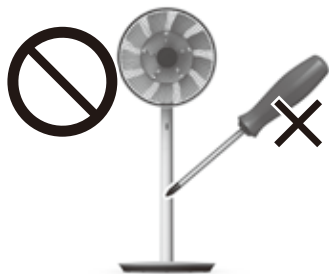

Do not disassemble or modify the product. Doing so may cause a malfunction, fire, or electric shock.

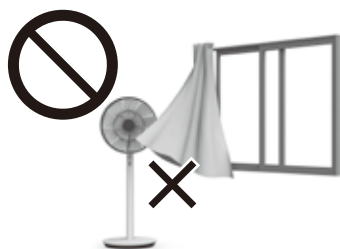

Make sure curtains and the like do not become entangled. Doing so may cause a malfunction or accident.



Be careful not to pinch yourself on the moving parts or connection parts.

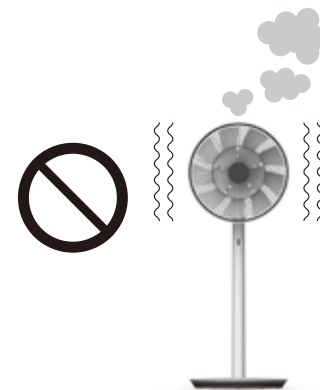

In the event of a malfunction, discontinue use and request an inspection.

To request an inspection of your fan, contact the BALMUDA Europe Service Center (P. 26).



Do not insert fingers or foreign objects inside the Guard or moving parts. Doing so may cause injury.













Do not place the fan on uneven or unstable surfaces. Injury or malfunction may occur if the fan falls over.





Do not use any AC adapter other than the one included. Doing so may cause malfunction or fire.

Warning

-  **Do not disassemble except for maintenance purposes.**
Doing so may cause fire, electric shock, or injury.
-  **Do not use the cord or power plug if damaged or if incapable of being firmly inserted into the power outlet.**
Doing so may cause a short-circuit, electric shock, or fire.
-  **Do not damage, modify, bend, pull, twist, or bundle the cord. Do not place heavy objects on top of or pinch the cord.**
Doing so may cause a short-circuit, electric shock, or fire.
-  **Do not operate without attaching the Fan or the Fan Guard.**
Doing so may cause injury.
-  **Do not allow water or foreign objects inside the product.**
Intrusion of water or foreign objects may cause fire or electric shock. If water or foreign objects enter the fan, immediately unplug the fan or remove the Battery Pack (sold separately) if used.
-  **Do not touch the + or – terminals of the remote control battery to wires or other metal. Do not transport or store with metallic necklaces, hair pins, etc.**
Doing so may cause overheating, rupture, or ignition.
-  **Make sure the power supply to the AC adapter is 220-240 VAC. Also note that this product is for use in Europe only.**
Failure to do so may cause fire or electric shock.
-  **Insert the power plug completely.**
Failure to do so may cause fire or electric shock.
-  **Unplug the product when not in use.**
Failure to do so may cause electric shock, electric leakage fire, or injury.
-  **When unplugging the power plug from the power outlet, pull on the AC adapter and never pull on the cord. Also, never allow dust to settle on the power plug**
Doing so may cause a short-circuit, electric shock, or fire.
-  **This appliance must only be supplied at safety extra low voltage corresponding to the marking on the appliance.**

Caution

-  **Do not use the product in the following places. Doing so may cause electric shock or fire.**
 - Near a gas stove or open flame
 - Near flammable gases
 - Near water or rain
-  **Do not expose your body to the wind for an extended period of time.**

Excessive decreases in temperature can be harmful to your health.
-  **Do not plug in or unplug the product with wet hands.**

Doing so may cause electric shock or injury.
-  **Do not expose the product to water.**

Water may cause short circuits or electric shock.
-  **Do not use sprays or liquids on the product.**

Inflammable sprays may cause fire or explosion.
Other sprays may damage the plastic or paint.
-  **Do not allow children or individuals who require assistance to operate the product, and do not place in a location accessible by young children.**

Doing so may cause electric shock or injury.
-  **Do not drop or subject the product to strong impacts.**

Doing so may cause malfunction or damage.
-  **Do not use or store in direct sunlight or locations with high temperatures or humidity.**

Doing so may cause deformation, discoloration, or corrosion of the battery.
-  **Stop use immediately if malfunctions such as overheating, irregular shape, or abnormal odors occur.**

Failure to do so may cause overheating, explosion, fire, or corrosion of the battery.
-  **Children shall not play with the appliance.**

Cleaning and user maintenance shall not be made by children without supervision.
Doing so may cause electric shock or injury.
-  **Always unplug the product before performing maintenance. To clean the product after attaching the Battery Pack (sold separately), remove the Battery Pack from the main unit.**

Failure to do so may cause electric shock or injury.
-  **This appliance can be used by children aged from 8 years and above and persons with reduced physical, sensory or mental appliance in a safe and understand the hazards involved.**

Package Contents

The number in the parentheses indicates the number of products.

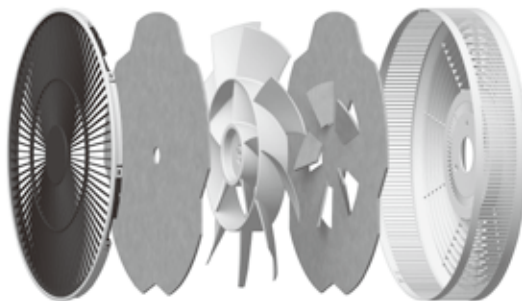
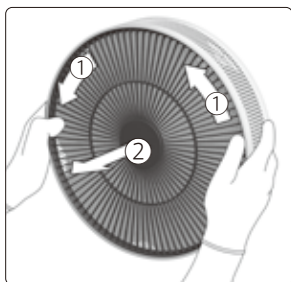

Unpacking the Fan Guard

Rotate the Front Fan Guard (①) and pull (②) to remove.

Front Fan Guard (1)
Fan (1)
Side Guard (1)

Motor Unit (1)

Center Pole (1)

Instruction Manual/Warranty (1)



Base Unit (1)
Battery Cover (1)



AC Adapter (1)



Fan Holder (1)



Guard Holder (1)



Remote Control (1)
Button battery inside (1)
* Test battery

Assembly of the Head Unit

- 1** Fix the Side Guard to the Motor Unit with the Guard Holder.

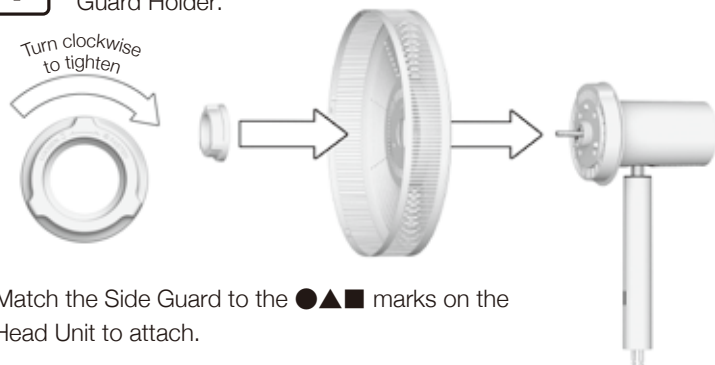

* Match the Side Guard to the ●▲■ marks on the Head Unit to attach.

- 2** Secure the Fan using the Fan Holder.

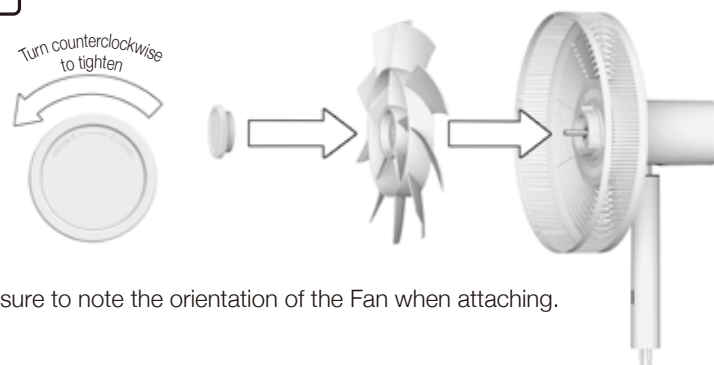

* Be sure to note the orientation of the Fan when attaching.

- 3** Attach the Front Fan Guard.

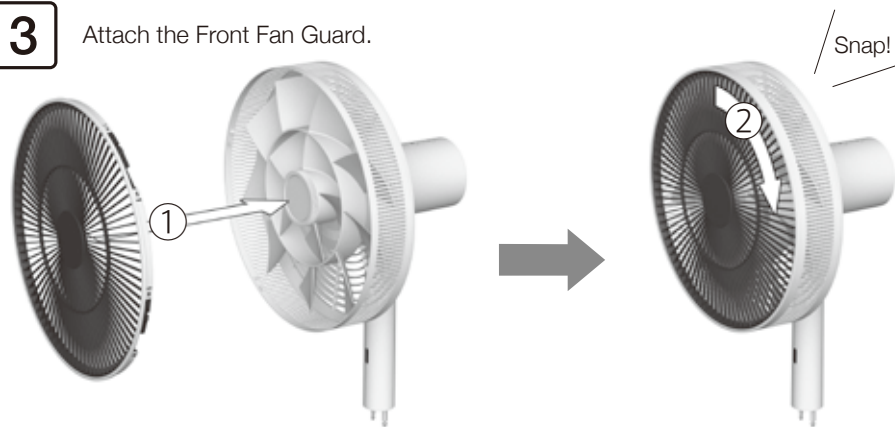

① Attach the Front Fan Guard onto the Side Guard.

② Rotate the Front Fan Guard until tight.

* Use thick gloves when performing steps **2** and **3**.

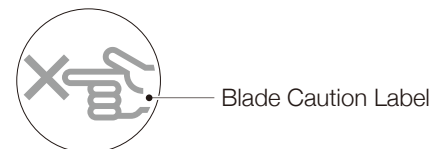

* Do not remove the Blade Caution Label attached to the Fan.

* Using the fan with the Guard attached incorrectly is extremely dangerous. Make sure the Guard is firmly secured before use.

Assembly

1 Insert the Center Pole into the Base Unit.

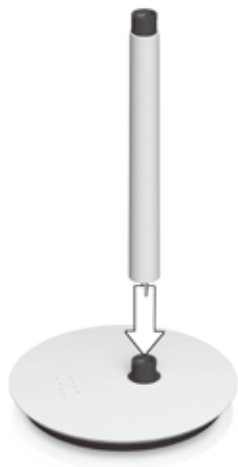

2 Insert the assembled Head Unit into the Center Pole.

Inserting the shaft joints into the holes

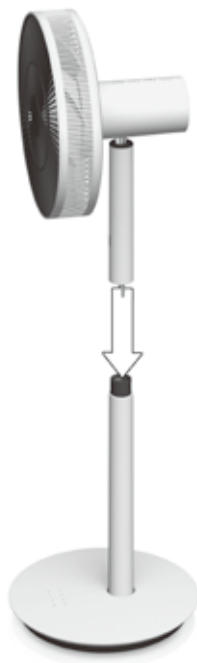
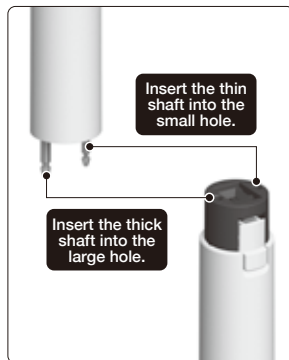

- * No electric current flows through the shafts.
- * Inserting the shaft will not be possible if the wrong hole is used.
- * Make sure neither pole can be removed without pressing the Lock Release button.
- * Be careful not to pinch yourself when connecting the components.
Insert firmly until a "Click!" can be heard.

3 Connect the AC adapter plug.

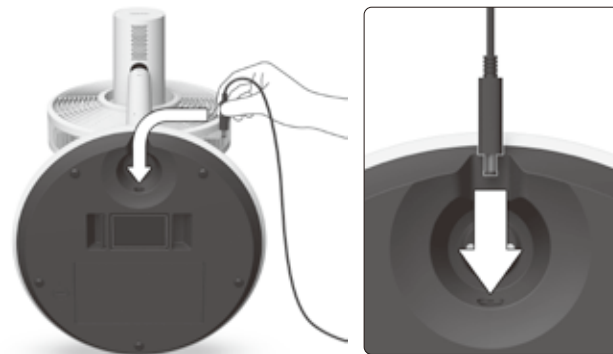

4 Connect the AC adapter to an outlet.



- * A beep will be heard if the AC adapter is connected correctly.
- * No beep will be heard when connecting the AC adapter if the Battery Pack (sold separately) is installed.

Using in the Short Size

This product can be used in the Tall Size as a stand fan, or in the Short Size as a desk fan.



! Be sure to remove the AC adapter or Battery Pack (sold separately) before proceeding.

Re-Assembly

1 Press the Lock Release button to remove the Head Unit.

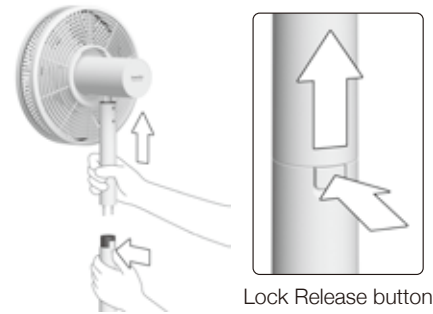

2 Remove the Center Pole while pressing the Lock Release button on the underside of the Base.

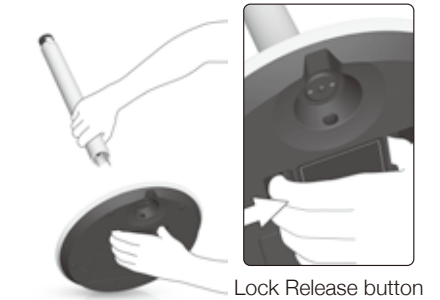

3 Insert the Head Unit into the Base Unit.

- * Inserting the shaft will not be possible if the wrong hole is used.
- * Make sure neither pole can be removed without pressing the Lock Release button.
- * Be careful not to pinch yourself when connecting the components. Insert firmly until a "Snap!" can be heard.



Operating Instructions

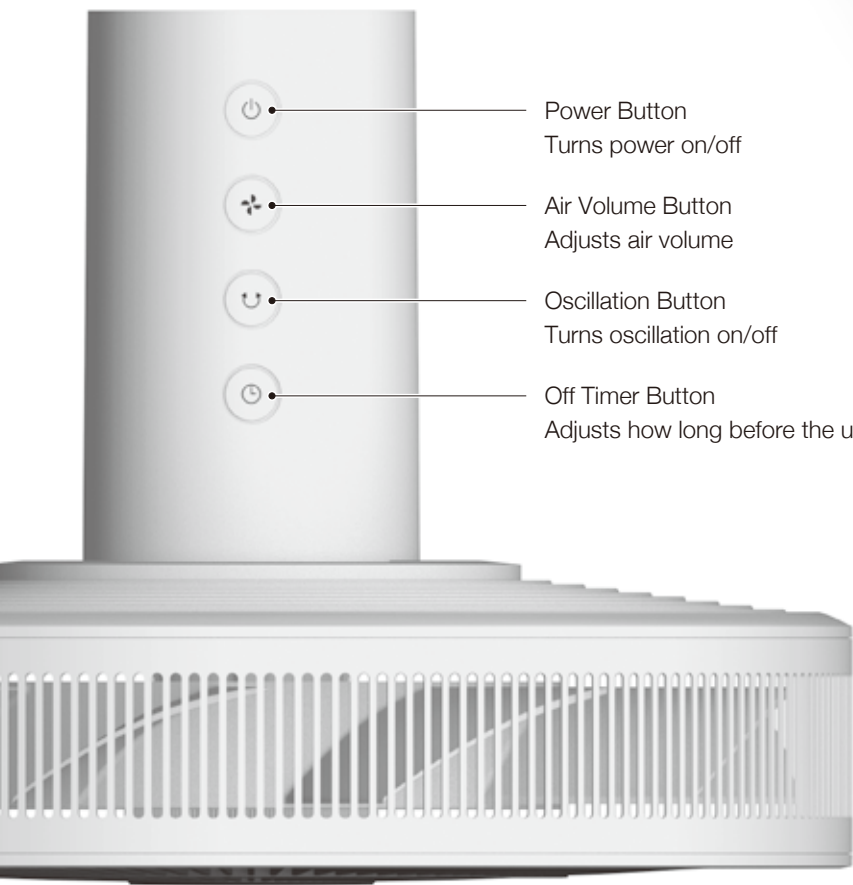

- Power Button
Turns power on/off
- Air Volume Button
Adjusts air volume
- Oscillation Button
Turns oscillation on/off
- Off Timer Button
Adjusts how long before the unit turns off

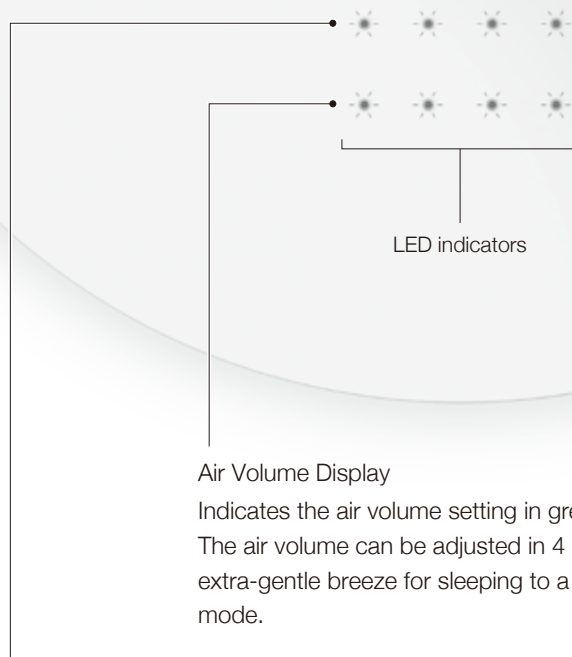

Air Volume Display

Indicates the air volume setting in green lights. The air volume can be adjusted in 4 steps, from an extra-gentle breeze for sleeping to a strong circulator mode.

Off Timer Display

Indicates how long until the unit turns off (from left; 1, 2, 3, or 4 hours) in slow-blinking green lights.

* This product is equipped with a 12-Hour Auto Off function that automatically turns the power off after 12 hours with no operation. This Auto Off function cannot be disabled.

* The LED indicators will dim after 1 minute if the fan is not operated.

Manual Angle Adjustment

In addition to automatic oscillation, the oscillation angle of the fan can be adjusted up, down, left, or right by hand.

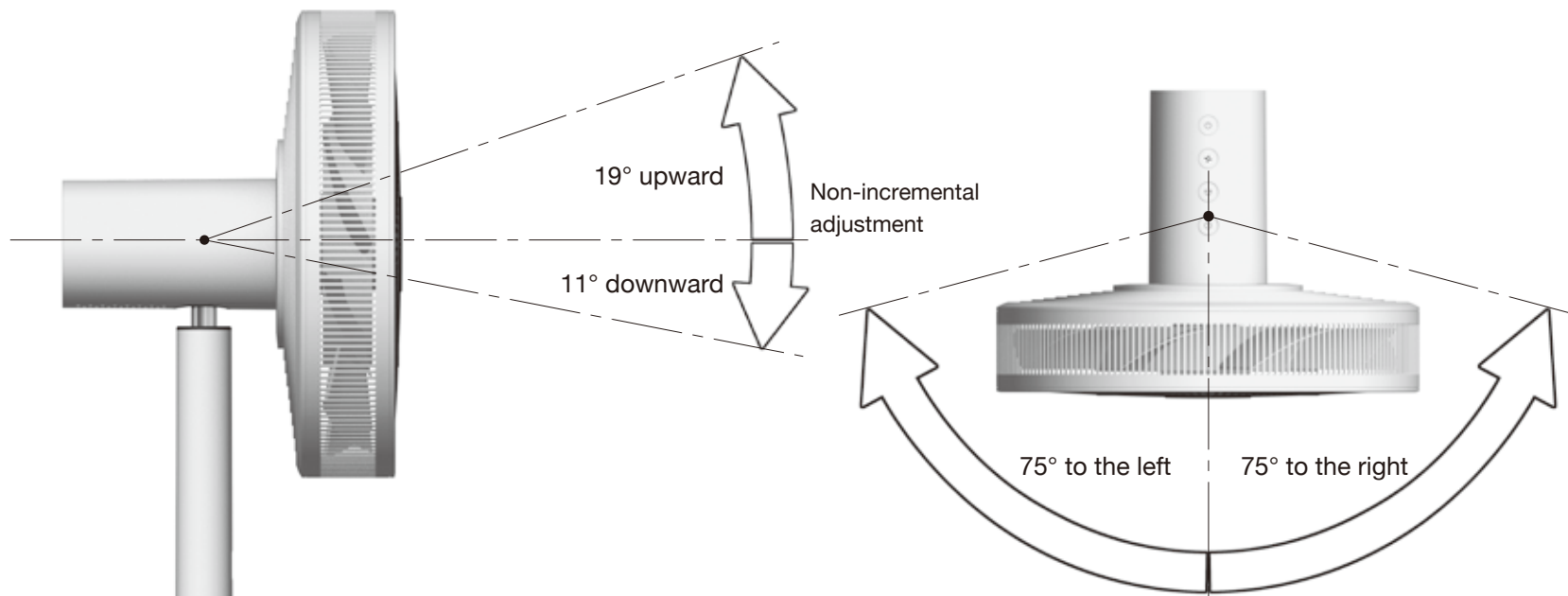

* Vertical adjustments are non-incremental.

* Do not move the fan beyond the above angles when manually adjusting the angle. Doing so may damage the fan.

* Make sure no children are in the vicinity when setting the oscillation angle. Failure to do so may lead to unintended injury such as from the fan hitting the children in the head.

Automatic Oscillation Angle Setting

The automatic oscillation angle of this product can be set as desired.

To set the angle, rotate the Head Unit to the left and right during automatic oscillation operation to set **Point A** and **Point B**. Once set, the fan will oscillate automatically between Point A and Point B.

Example 1 The automatic oscillation angle can be set up to 150°.

1 Press the Oscillation button to begin oscillation.

* Setting the automatic oscillation angle is possible only while the fan is oscillating.



2 With your hands on the Side Guard, quickly rotate the fan to set **Point A**.

* Point A can be set to either the left or the right.

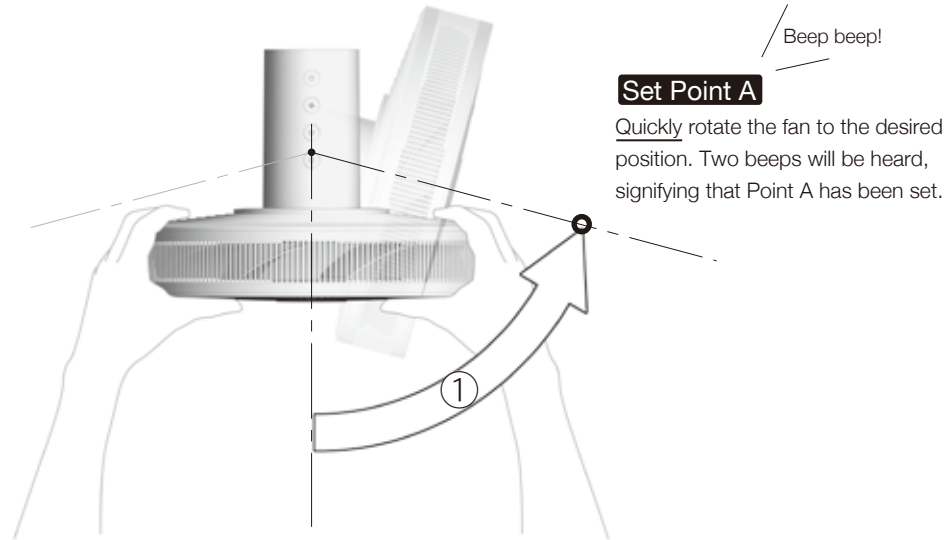

* The automatic oscillation angle is set to 80° when shipped from the factory. The setting will return to the factory default if the AC adapter is disconnected.

* During automatic oscillation operation or when setting the automatic oscillation angle, fan operation will stop if oscillation is prevented for a certain period of time. This is a safety feature of The GreenFan. To release the safety feature, turn the power off and back on.

- 3** After setting **Point A**, quickly rotate the fan to the desired position to set **Point B**. When two beeps are heard, the automatic oscillation angle has been set.

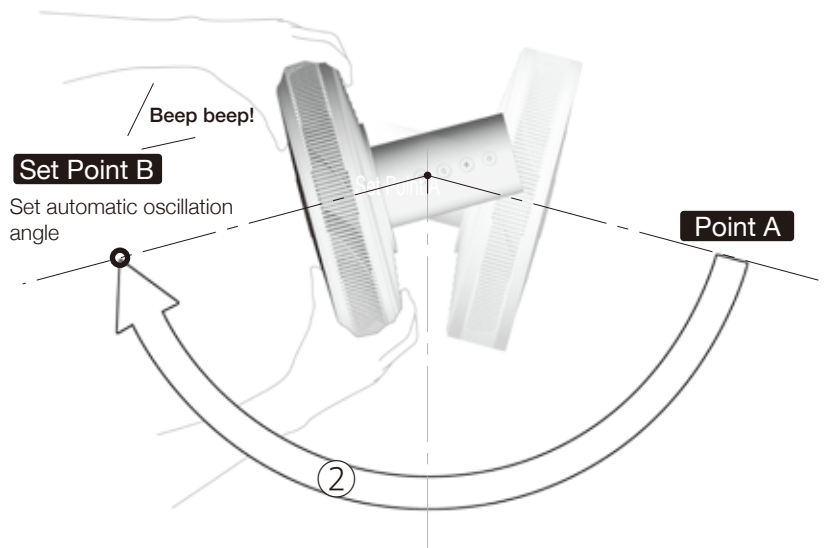

* When the fan is turned off, the Head will move to the center automatically. When the power is turned back on, automatic oscillation at the previously set angle will begin.

Example 2 The automatic oscillation angle of this product can be set as desired.

* The minimum oscillation angle is 30°. If the angle between Point A and Point B is less than 30°, the automatic oscillation angle will be set to 30°.

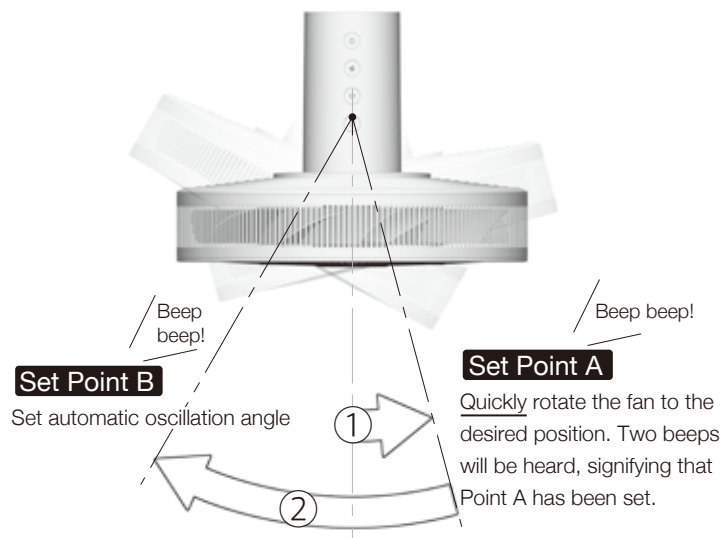

Visit the BALMUDA homepage for a video on how to set the automatic oscillation angle.
<http://www.balmuda.com/de/greenfan/design>

Using the Remote Control

The buttons on the remote control enable the same operation as the buttons on the fan. (P. 11)

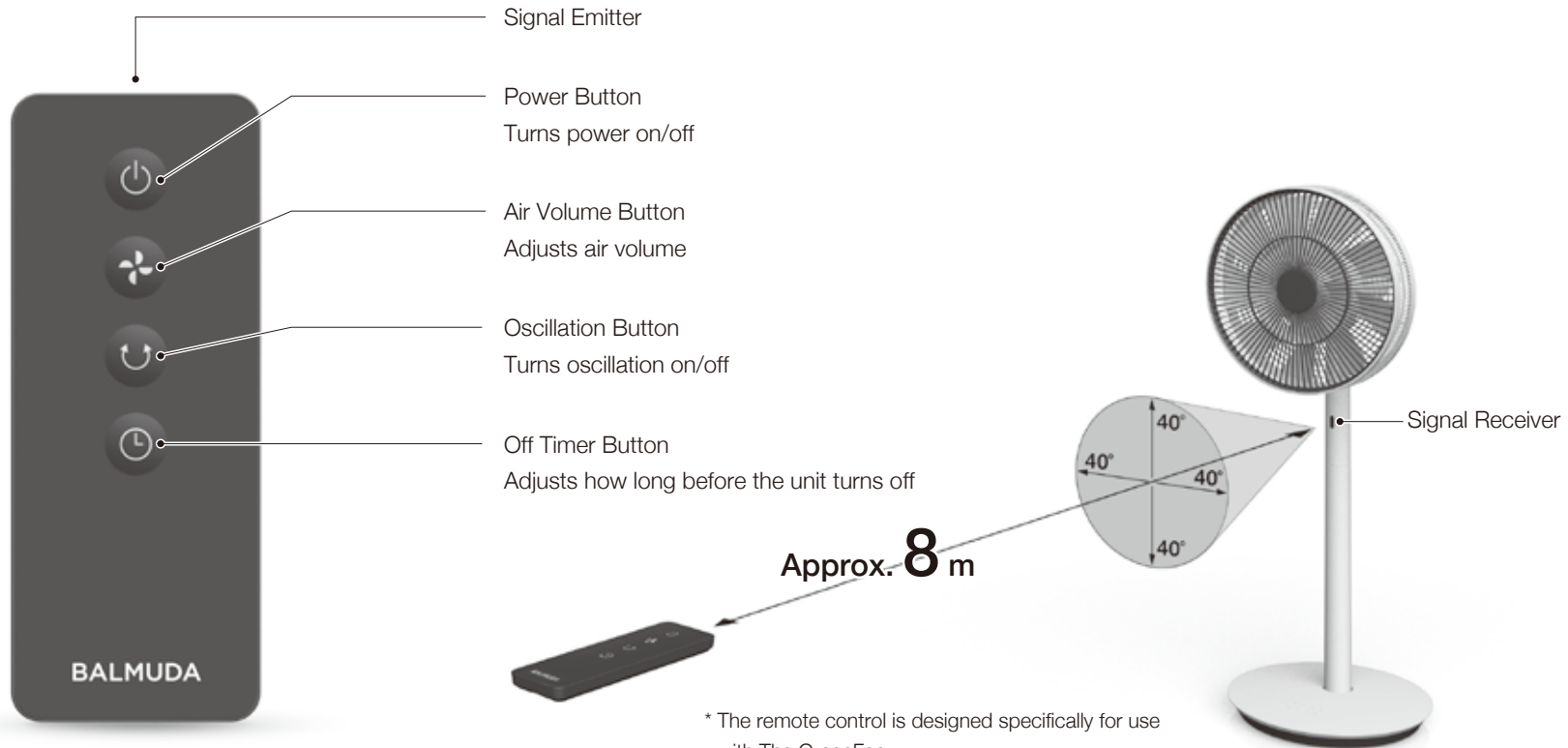

* The remote control is designed specifically for use with The GreenFan.

* The distance and angle figures displayed above are for reference only.

* Point the signal emitter at the signal receiver on the fan to use the remote control.

A battery is included inside the remote control when shipped from the factory. Pull the insulating sheet in the direction indicated by the arrow to use the remote control.

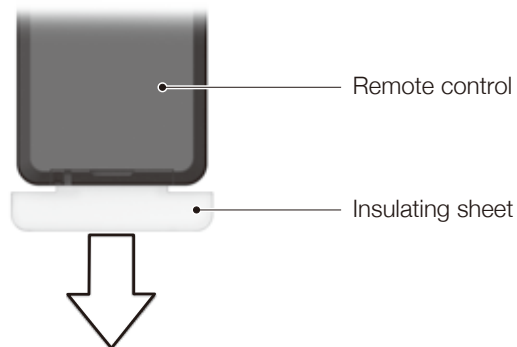

Replacing the Batteries

Pull while pressing on the latch.

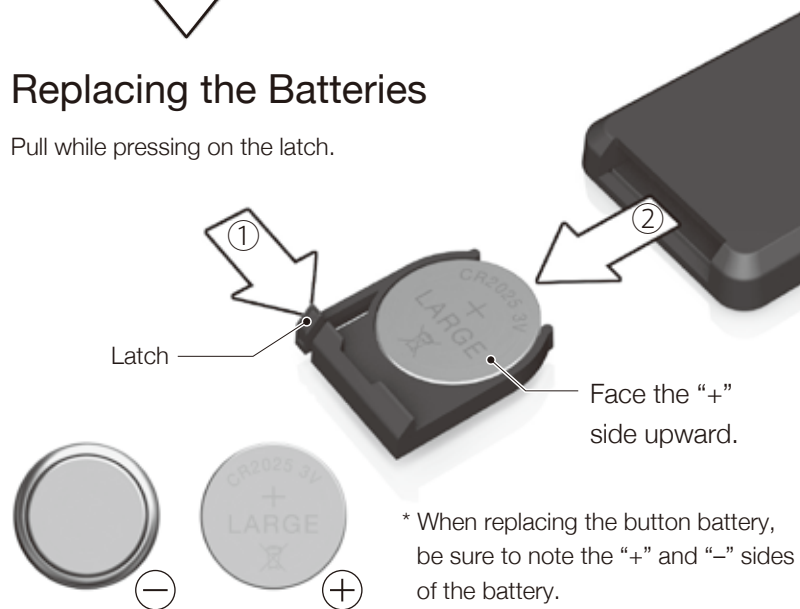

Read the following precautions on using the remote control to ensure correct usage.

- Do not allow the signal receiver on the fan to be directly exposed to sunlight or strong light from lighting equipment. Operation may not be possible in such conditions.
- Do not obstruct the signal receiver. Any obstacles between the remote control and the signal receiver on the fan will prevent operation via the remote control.
- Replace the battery if the operation response of the remote control declines.
- Use only a button-cell battery (CR2025, 3 V) for the remote control.
- Remove the battery from the remote control if the remote control will not be used for extended periods. Failure to do so may cause the batteries to become corroded.

NOTICE

- Keep the remote control (specifically the battery) out of reach of children. Contact a doctor immediately if the battery is ingested.
- If corrosion from the battery enters the eye, do not rub the eye and wash thoroughly with clean water such as tap water, and seek medical attention immediately. Corrosion may cause permanent damage to the eyes.
- If corrosion from the battery comes into contact with skin or clothing, rinse immediately with clean water such as tap water. Failure to do so may cause skin rash.
- Corrosion from the battery may stain cloth, leather, furniture, flooring, or other objects if coming into contact. Take sufficient care.
- Be sure to follow local waste disposal sorting guidelines when disposing of batteries. (Apply cellophane tape to the "+" and "-" sides of the battery before disposal.)

Using the AC Adapter

BALMUDA Multi-Plug AC Adapter

The Plug Unit on the BALMUDA Multi-Plug AC Adapter can be plugged into an outlet in four ways, letting you choose the best fit for the outlet.

Up



Right

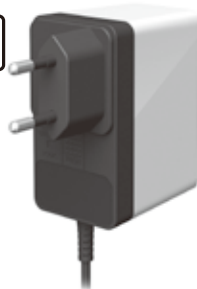

Down

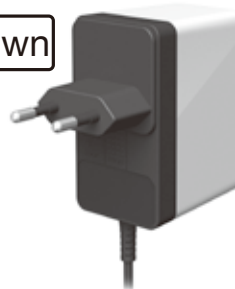

Left

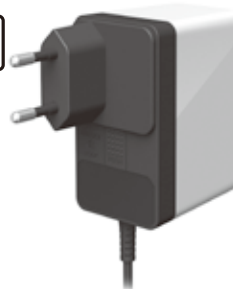

Removal

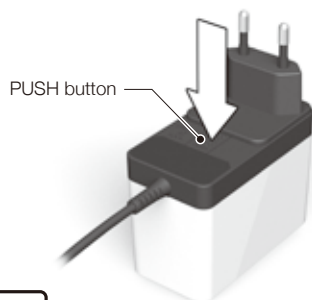

PUSH button

1

Press the PUSH button.

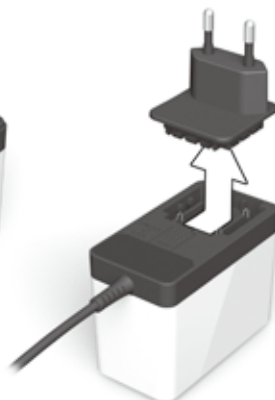

2

Slide and lift.

Attachment

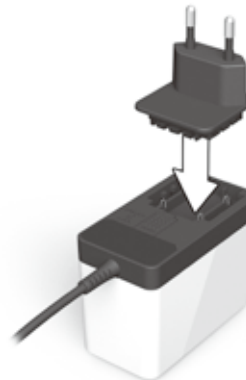

1

Attach the plug unit.

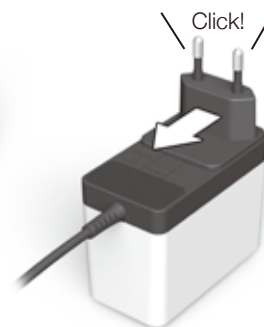

Click!

2

Slide in the Lock direction until a "Click!" is heard.

Maintenance

BALMUDA recommends performing maintenance on the fan once every two weeks.

! When performing maintenance, be sure to remove the AC adapter or Battery Pack (sold separately) before proceeding.

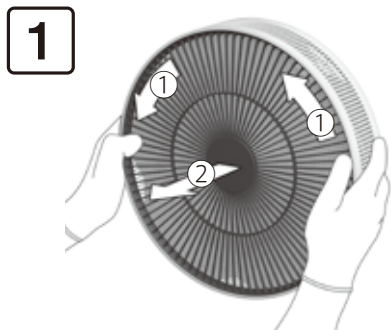

Rotate the Front Fan Guard (①) and pull (②) to remove.

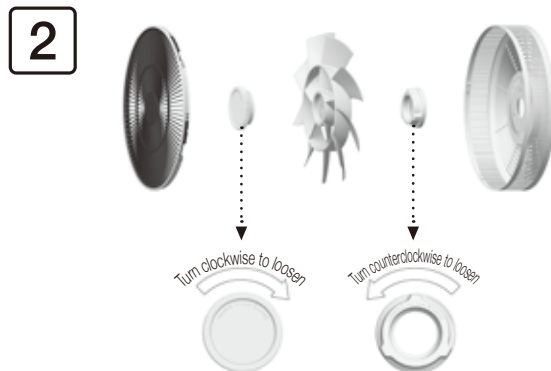

* Use thick gloves when performing steps **1** and **2**.

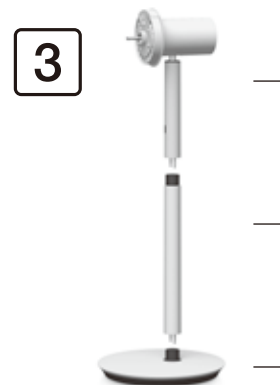

Refer to P. 10
"Re-Assembly"
for information
on disassembly.



Parts That Can Be Washed

Use diluted mild kitchen detergent with a soft cloth or a sponge to wash the parts.

* After washing, dry the parts thoroughly before use.



Parts That CANNOT Be Washed

Wipe gently with a soft, dry cloth.

* Never wash the following parts.

* Do not use organic solvents such as thinner or benzene, cleansers, alkaline detergents, or alcohol.



Using the Battery & Dock (Sold Separately)

! Unplug the AC adapter when attaching the battery.

The Battery & Dock allows the fan to be used as a cordless device.

* When using the Battery & Dock, be sure to read and follow the included instruction manual.

Installation

1 Remove the Battery Cover.

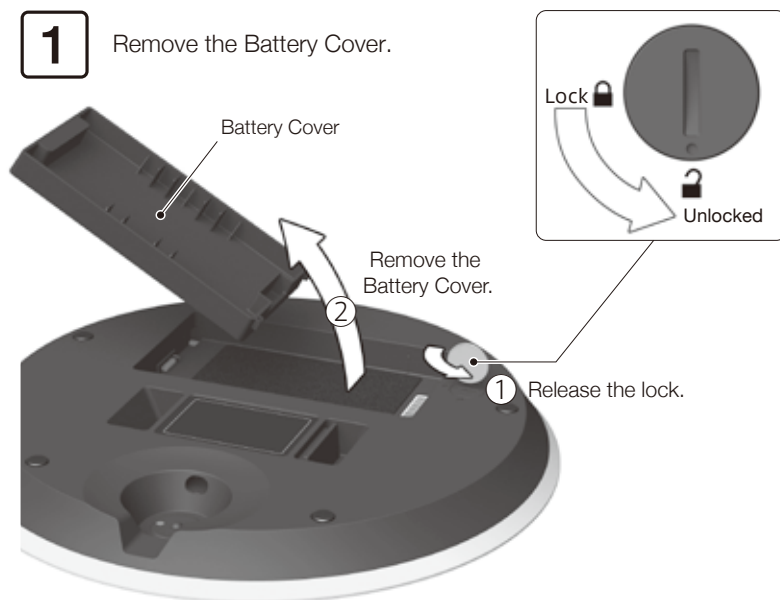

* Use a coin or the like to release the lock.

* Do not lose the Battery Cover. It will be required when removing the Battery Pack.

* If the Battery Cover or Battery Pack is difficult to remove, place the Base Unit on the floor and remove by hand.

Battery & Dock
EGF-P100 Series
(Sold separately)

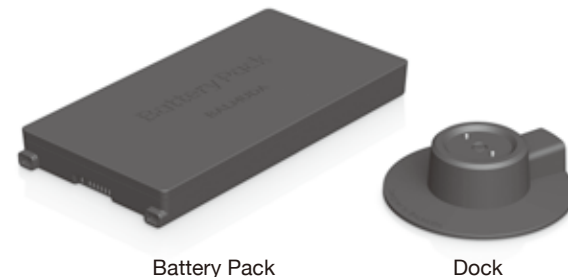

2 Attach the Battery Pack.

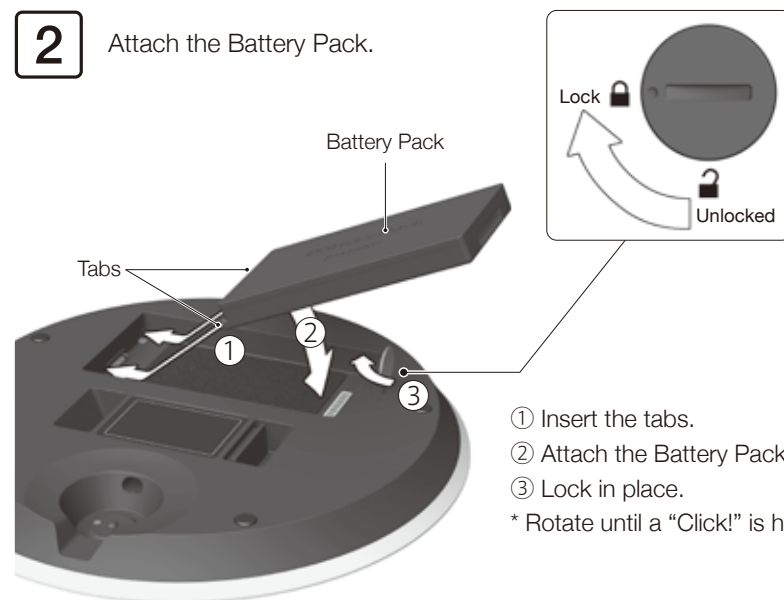

! Be sure to lock the Battery Pack in place after attachment.
Malfunction or injury may occur if the Battery Pack falls out.

3 Connect the AC adapter plug to the Dock.

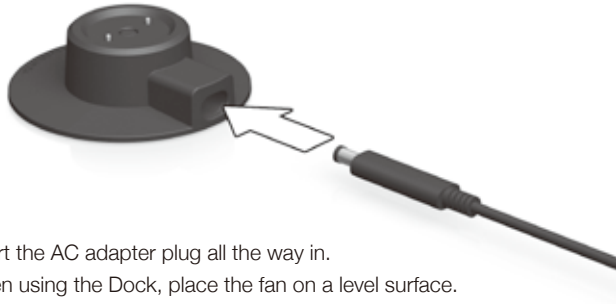

! Insert the AC adapter plug all the way in.
When using the Dock, place the fan on a level surface.

5 Connect The GreenFan to the Dock.

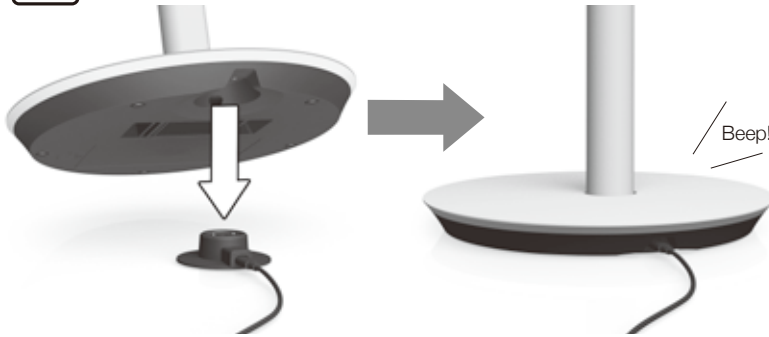

* Align the dimple on the underside of the Base Unit to the Dock, and slowly place the fan on top.

* The fan must be connected to the Dock to charge the Battery Pack. Connecting the AC adapter directly to The GreenFan without using the Dock will result in the Battery Pack not being charged.

* The green and white LEDs will illuminate when operating the fan with the Dock connected. When the fan is disconnected from the Dock for cordless use, only the green LEDs will illuminate.

4 Connect the AC adapter to an outlet.

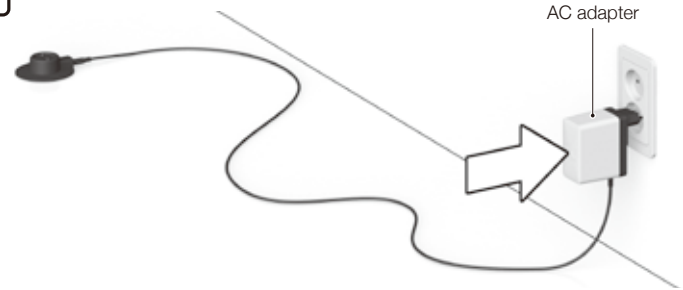

! Be sure to use the AC adapter included with The GreenFan.
Use of a different AC adapter may cause a malfunction or breakdown.

Checking the Remaining Battery Power

Pressing the Power button on the fan for at least 2 seconds during operation will show the remaining battery power.

* The LED indicators will flash green.

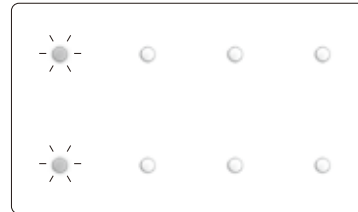

Battery power is "1" (less than 25%)

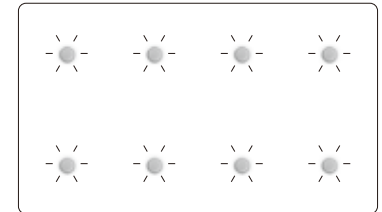

Battery power is "4" (more than 75%)

* Checking the remaining battery power is not possible if the fan is not turned on.

* The remaining battery power may change depending on the usage conditions such as the air volume or if The GreenFan is used connected to the Dock.

Storing the Product

Please store the product as shown below.

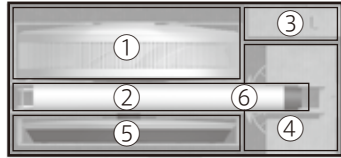

Packaging view from above

1

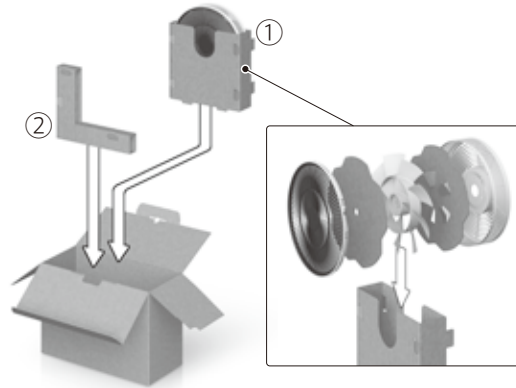

2

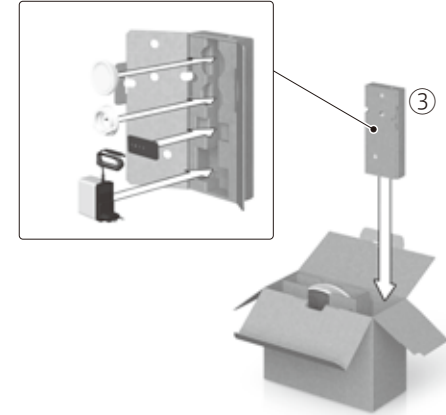

3

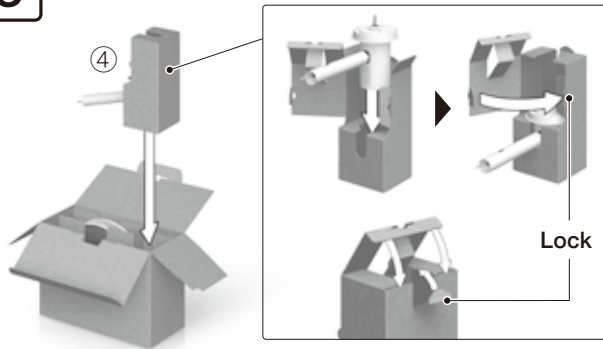

4

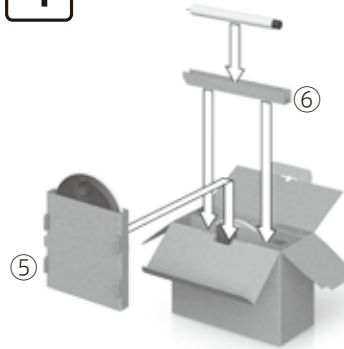

* To ensure safety, store the Battery Pack (sold separately) and the fan separately.

* Charge the Battery Pack (sold separately) once every six months (recommended) when storing it to ensure the maximum life of the product.



- To prevent battery corrosion, remove the battery when the remote control will not be used for extended periods.
- Store in a cool location away from direct sunlight with no high temperatures or humidity.

Product Specifications

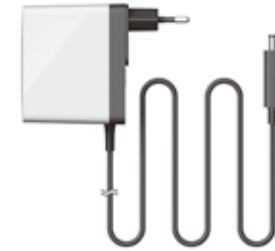
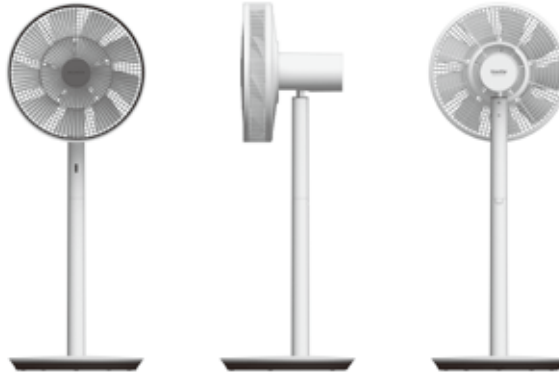

Fan

Product Name	The GreenFan
Model	EGF-1600 Series
Voltage	12 VDC
Power Consumption	Max. 20 W
Max. RPM	775 rpm
Dimensions (W × D × H)	330 × 320 × 871/497 mm
Off Timer	1, 2, 3, or 4 hours
Weight	Approx. 4.1 kg
Intended Usage	For home use

AC Adapter

Rated Input Voltage	100–240 VAC
Rated Input Capacity	79–93 VA
Rated Frequency	50/60 Hz
Rated Output Voltage	12 VDC
Rated Secondary Electric Current	3 A
Cord Length	Approx. 1.8 m

* Power consumption and RPM are measured with the air volume set to level 4.

* Specifications and appearance are subject to change without notice for improvement purposes.

Troubleshooting

After reviewing the suggestions in this section, if the problem persists, contact the BALMUDA Europe Service Center (P. 26).

Problem	Points to Check	Possible Solutions	Page
Operation will not start when pressing the Power button	<ul style="list-style-type: none"> ● Has a fuse blow or breaker been tripped in your home? ● Is the AC adapter properly plugged into the power outlet? ● Is the AC adapter plug firmly connected to the connector on the fan? ● Is the Fan attached with the correct orientation? ● Is the Battery Pack (sold separately) charged? 	<ul style="list-style-type: none"> ▶ Check your fuses and breaker. ▶ Ensure the AC adapter is plugged into the power outlet properly. ▶ Ensure the AC adapter plug or multi-plug is inserted securely. ▶ Re-attach the Fan correctly. ▶ Charge the Battery Pack (sold separately). 	<div style="display: flex; flex-direction: column; gap: 10px;"> <div style="border: 1px solid black; padding: 2px 5px; background-color: #f0f0f0;">P. 9</div> <div style="border: 1px solid black; padding: 2px 5px; background-color: #f0f0f0;">P. 8</div> <div style="border: 1px solid black; padding: 2px 5px; background-color: #f0f0f0;">P. 19</div> </div>
Fan operation is noisy	<ul style="list-style-type: none"> ● Is the Fan firmly secured with the Fan Holder? ● Is the Fan facing the right way? ● Is the Guard bumping against the Fan? 	<ul style="list-style-type: none"> ▶ Attach the Fan correctly. ▶ Check the orientation of the Fan and re-attach if necessary. ▶ Make sure the Fan and Fan Guard are firmly attached. 	<div style="border: 1px solid black; padding: 2px 5px; background-color: #f0f0f0;">P. 8</div>
The airflow has decreased	<ul style="list-style-type: none"> ● Has dust accumulated on the Fan or Guard? 	<ul style="list-style-type: none"> ▶ Airflow efficiency declines when dust accumulates around the Fan Guard. BALMUDA recommends cleaning once every two weeks. 	<div style="border: 1px solid black; padding: 2px 5px; background-color: #f0f0f0;">P. 18</div>
Can't fasten the Fan Holder	<ul style="list-style-type: none"> ● Are you turning the Fan Holder in the right direction to secure? 	<ul style="list-style-type: none"> ▶ The Fan Holder must be rotated in the correct direction to attach. Turn the Fan Holder counterclockwise to fasten. 	<div style="border: 1px solid black; padding: 2px 5px; background-color: #f0f0f0;">P. 8</div>
The oscillation sound is disturbing	<ul style="list-style-type: none"> ● When oscillating, does the fan temporarily exhibit strong clicking or grinding sounds? 	<ul style="list-style-type: none"> ▶ The oscillation motor has a unique sound that may be interpreted as a malfunction. 	
Oscillation is unbalanced toward the right or left	<ul style="list-style-type: none"> ● Have you adjusted the automatic oscillation angle? 	<ul style="list-style-type: none"> ▶ Adjust the automatic oscillation angle. 	<div style="border: 1px solid black; padding: 2px 5px; background-color: #f0f0f0;">P. 13</div>
Operation stopped automatically	<ul style="list-style-type: none"> ● Have you set the Off Timer? ● Have 12 hours passed since last operating the fan? 	<ul style="list-style-type: none"> ▶ Double-check the Off Timer setting. ▶ To ensure safety, the product has a 12-hour Auto Off function. 	<div style="border: 1px solid black; padding: 2px 5px; background-color: #f0f0f0;">P. 11</div> <div style="border: 1px solid black; padding: 2px 5px; background-color: #f0f0f0;">P. 11</div>

Problem	Points to Check	Possible Solutions	Page
The remote control doesn't work	<ul style="list-style-type: none"> ● Is the battery old? ● Is the battery oriented correctly? ● Are you pointing the remote control toward the signal receiver? ● Are you operating the remote control within the effective distance? ● Is the signal receiver directly exposed to strong light? 	<ul style="list-style-type: none"> ▶ Replace the batteries. ▶ Check the orientation of the batteries. ▶ Review the location of the signal receiver on the fan. ▶ Ensure the remote control is used within 8 m. ▶ Make sure the signal receiver is not exposed to strong light. 	<ul style="list-style-type: none"> ▶ P. 16 ▶ P. 16 ▶ P. 15 ▶ P. 15 ▶ P. 16
The fan seems to shake unnaturally	<ul style="list-style-type: none"> ● Has the Blade Caution Label attached to the Fan been removed? 	<ul style="list-style-type: none"> ▶ The fan is designed to be balanced with the fan label attached. ▶ The GreenFan is designed with a multiple-blade fan that results in pronounced shaking if the fan is out of balance. Note, however, that all shipped products have passed quality inspection. 	
The LED indicators for the Air Volume Display and Off Timer Display on the Base Unit are flashing	<ul style="list-style-type: none"> ● Is the first LED indicator from the left of the Off Timer Display (P. 11) flashing? 	<ul style="list-style-type: none"> ▶ Oscillation is not possible. Switch the power to the fan off and make sure nothing is hindering oscillation. 	
	<ul style="list-style-type: none"> ● Is the second LED indicator from the left of the Off Timer Display (P. 11) flashing? 	<ul style="list-style-type: none"> ▶ The fan blade cannot rotate. Switch the power off and make sure the product is assembled properly. ▶ The LED indicator may flash if the Battery Pack (sold separately) has low remaining power. Charge the Battery Pack (sold separately) fully before using. 	<ul style="list-style-type: none"> ▶ P. 8 ▶ P. 19
	<ul style="list-style-type: none"> ● Are any other LED indicators flashing? 	<ul style="list-style-type: none"> ▶ Unplug the AC adapter or Battery Pack (if used) and wait 5 seconds before reconnecting. If the problem persists, check which LED indicators are flashing, and contact the BALMUDA Europe Service Center. 	<ul style="list-style-type: none"> ▶ P. 9 ▶ P. 19 ▶ P. 26
The LED indicator on the Base Unit have dimmed	<ul style="list-style-type: none"> ● Has the fan not been operated for more than 1 minute? 	<ul style="list-style-type: none"> ▶ The LED indicator will dim after 1 minute if the fan is not operated. 	<ul style="list-style-type: none"> ▶ P. 11
The oscillation angle is narrower than the customized angle	<ul style="list-style-type: none"> ● Was the AC adapter disconnected or the Battery Pack (sold separately) removed? ● Is the fan tilted? 	<ul style="list-style-type: none"> ▶ The automatic oscillation angle will return to the factory default if the fan is disconnected from the power supply. ▶ Place the fan on a level surface for use. 	<ul style="list-style-type: none"> ▶ P. 13

Warranty and After-Purchase Service

For inquiries on repairs, usage, or maintenance, please call the BALMUDA Europe Service Center (p26), or contact your dealer.

1. Please receive the warranty card from your dealer with the purchase date and the dealer name filled in.
2. The warranty is valid for 2 years from the date of purchase. For repairs, please contact the BALMUDA Europe Service Center or your dealer. The repair will be carried out according to the warranty.
3. Contact the BALMUDA Europe Service Center or your dealer for out-of-warranty repairs. You can request for a repair with charge, if it enables the product to function properly.
4. Never attempt to repair or modify the product by yourself.

Handling of Personal Information

1. BALMUDA Inc. (hereinafter “BALMUDA”) may use personal information for customer service and repairs, and may keep a record of the inquiries.
2. BALMUDA will not disclose personal information to third parties, except in the following cases:
 - a. When repairs or confirmation of repairs are entrusted to third parties.
 - b. In cases pursuant to the provisions of laws and regulations.
3. For inquiries on personal information, please contact the BALMMUDA Europe Service Center.

See page 26 for information on BALMUDA Europe Service Center.

Disposal of waste batteries and electrical and electronic equipment



This symbol on the product, the battery or on the packaging indicates that the product and the battery shall not be treated as household waste. On certain batteries this symbol might be used in combination with a chemical symbol. The chemical symbols for mercury (Hg) or lead (Pb) are added if the battery contains more than 0.0005% mercury or 0.004% lead. By ensuring these products and batteries are disposed of correctly, you will help prevent potentially negative consequences for the environment and human health which could otherwise be caused by inappropriate waste handling. The recycling of the materials will help to conserve natural resources. Hand the battery over to the applicable collection point for the recycling of waste batteries. For more detailed information about recycling of this product or battery, please contact your local Civic Office, your household waste disposal service or the shop where you purchased the product or battery.

Notice for lithium batteries : Please hand only discharged batteries over to the collection point. Due to danger of short circuit, please patch the terminals of the battery with tape. Lithium batteries can be identified by the Li or CR marking on the battery.

Customer Service (for inquiries on usage, maintenance, repair)



 **040-897 25 35 15** (* Call charge required)

BALMUDA Europe Service Center

9:00-16:30, weekdays & business days only

 Online Inquiries



Please search the net with the keyword “BALMUDA,” or visit <https://www.balmuda.com/de/support/>.

* Please check the product model before inquiry.

Warranty

Model : EGF-1600-Series

Warranty Period:

2 years from the date of purchase

Body and AC Adapter (supplied)

Date of Purchase: Month Date Year

* **Customer Name**

Address

Tel. – –

* **Dealer**

Name/Address/Tel.

This warranty guarantees free repair of the product based on conditions stated herein.

Within the warranty period from the day of purchase, if the product proves defective despite normal use in compliance to the instruction manual, product label, and other warnings, BALMUDA will repair the product at no charge in accordance to this warranty. Please request for a repair by submitting the warranty card with the product at the BALMUDA Europe Service Center (see Instruction Manual P.24) or your dealer. Recycled parts compliant with our quality standard may be used for repair.

1. Repairs for the following cases will be conducted with charge, even during the warranty period:
 - a. Misuse, defect or damage due to modifications or improper repair, and repair conducted by unauthorized service organizations.
 - b. Damage caused by change of installation after initial setup, falling impact, removal, or transportation.
 - c. Damage caused by fire, earthquake, flood, lightning, or other natural disasters, pollution, abnormal voltage, and other external factors.
 - d. Damage, rust or mold caused by use or storage of product in vehicles, ships, places of extreme temperature, humidity, or dust.
 - e. Damage due to non-domestic (commercial) use.
 - f. Failure to present the warranty card.
 - g. No proof of purchase such as receipt etc. when the date of purchase, customer name, or dealer name are not written on the warranty card, or the content has been modified.
 - h. Use under conditions not written on the warranty, outdoor use, or any other unintended use or storage.
 - i. Damage due to soaking in water, exposure to alcohol, other liquid or gas, dust accumulation, or physical impact or pressure.
2. Defects on consumables and parts, or conditions that require cleaning are not applicable for returns.
3. Even during the warranty period, if the product has been sent for repair, or on-site support has been provided, the shipping/on-site service fee will be charged to the customer.
4. This warranty is only valid in Europe.
5. T his warranty will not be reissued. Please keep it in a safe place.
6. The content of this warranty does not apply to the extended warranty service provided by third parties.

This warranty guarantees free repairs for the stated period and conditions. The warranty does not limit the customer's legal rights to the warranty issuer, or any other agents.

BALMUDA Europe GmbH: Immermannstr. 13, 40210 Dusseldorf, Germany

BALMUDA Europe Service Center: 040-897 25 35 15



* G F P - P 0 0 6 - 0 2 - E U E - 0 1 0 *