

BALMUDA

Rain

Instruction Manual



ERN-1000SD Series

Important

Thank you for purchasing "Rain".

Before using this product, please be sure to read this manual and the Safety Precautions (P.34 to 38) thoroughly.

Furthermore, please be sure to follow the instructions adhered with the "!" mark on each page.

This manual also serves as a warranty card.

Be sure to store in a safe place after reading.

Contents

Before Use

Package Contents	4
Removing from the Package	5
Names of Parts	6
Assembly	7
Installation	11

How to Use

How to operate	12
Display	13
Operating Modes and 24h Timer	15
Filling with Water	16
Operating the Unit	17
Current Time	19
24h Timer Settings	20
Settings (Unit Settings)	21
Maintenance	23
Storage	25
Cleaning the Humidifying Filter	26
Replacing the Filter	27

Error Detection Function and Safety Functions

Error Detection Function and Safety Functions	29
Troubleshooting	31

AC adapter

For Safety

Safety Precautions	34
Warnings	35
Cautions	37

Specifications

If Problems Occur

Warranty and After Service	40
Handling of Customer Personal Information	40
Correct Disposal of this Product	40
FAQ	41
Inquiries	45

Package Contents

Number in () indicates the quantity.

Control Ring (1)



Water Supply Bowl Plate (1)

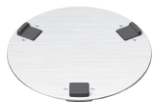

Main unit upper body (1)



Main unit lower body (1)



*The parts shown in the box on the right are preinstalled in the Water Supply Bowl before shipping.

Water Supply Bowl (1)



AC adapter (1)



Instruction manual (1)



Warranty card (1)



Enzyme Prefilter (1)

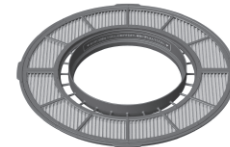

Humidifying Filter holder (1)

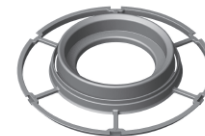

Humidifying Filter (1)

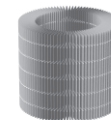

Silver ion cartridge (1)



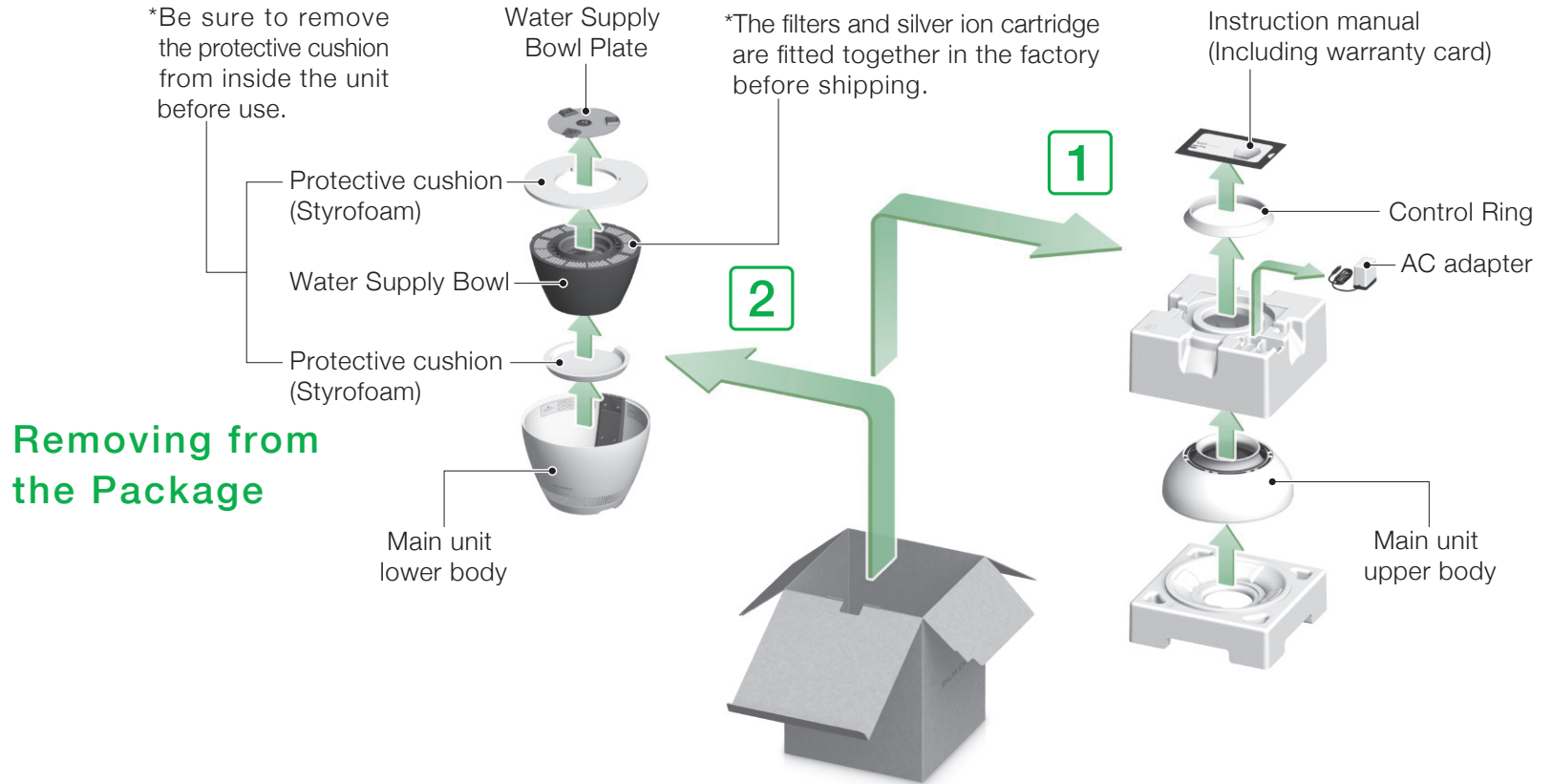

Remove from the packaging as shown in the illustration above.

*We recommend storing the packaging such as the cushion material and box for future storage or transportation of the unit.

Names of Parts

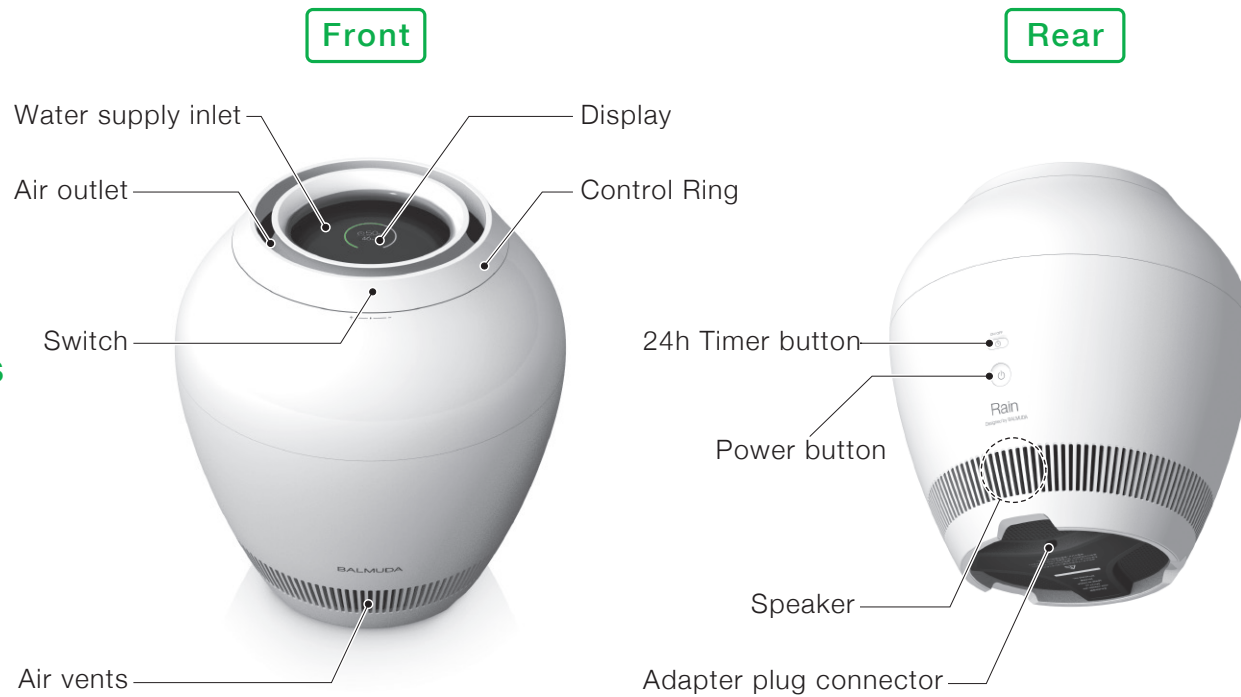

Assembly

Fit onto the protrusion at the center.



- 1** Set the silver ion cartridge on the protrusion at the bottom of the Water Supply Bowl.

 The silver ion cartridge will be attached to the Water Supply Bowl with tape when you unpack the unit. Be sure to remove the tape before using.

Set the filter so that the guide at the bottom of the Water Supply Bowl comes within the interior of the filter.

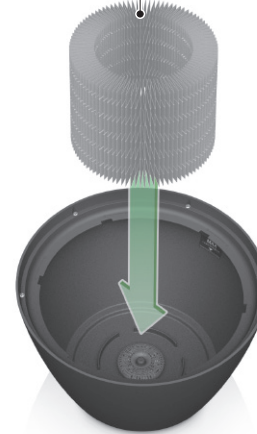
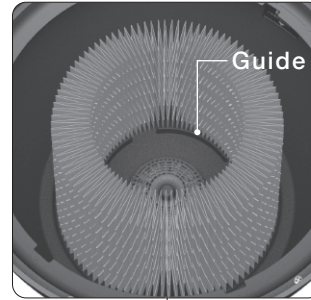

- 2** Set the Humidifying Filter at the center of the Water Supply Bowl, aligning it with the guide.

 The Humidifying Filter is packaged in a plastic bag. Be sure to remove the plastic bag before using.

Set the Humidifying Filter firmly to the Humidifying Filter Holder.

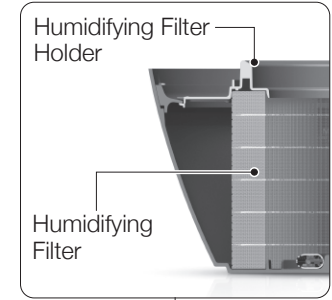

- 3** Align the claws of the Humidifying Filter Holder with the notches on the Water Supply Bowl.

Rotate firmly until the ○ marks are aligned.

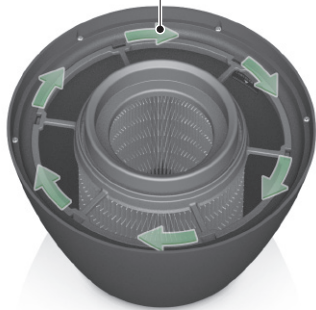
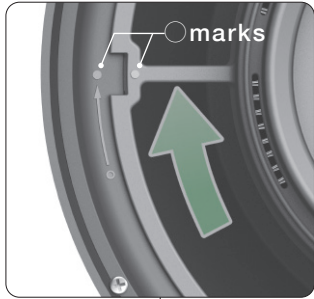

4 Rotate the Humidifying Filter Holder to lock it in place.

! Firmly lock the 6 claws in place. Improper assembly may cause malfunction.

Fully insert when connecting.

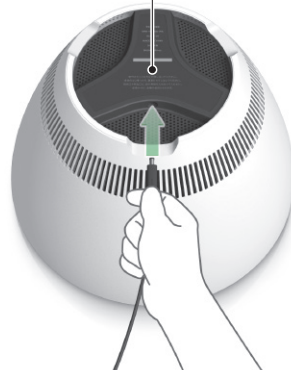

5 Connect the adapter plug.

! Do not connect the AC adapter to a wall outlet until assembly is complete.

Align the three protrusions and notches.

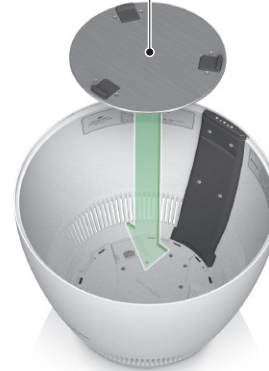
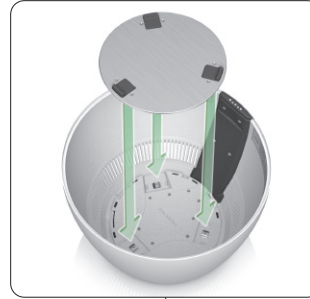

6 Set the Water Supply Bowl Plate.

Set the Water Supply Bowl so that it is flat.

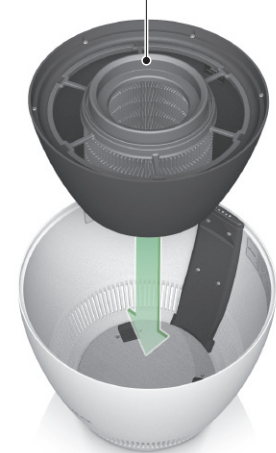
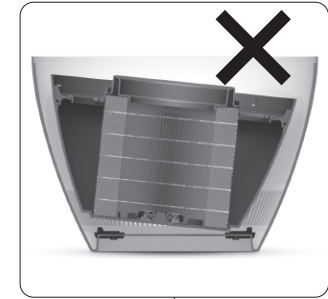

7 Set the Water Supply Bowl.

Push the Enzyme Prefilter in firmly until it clicks.

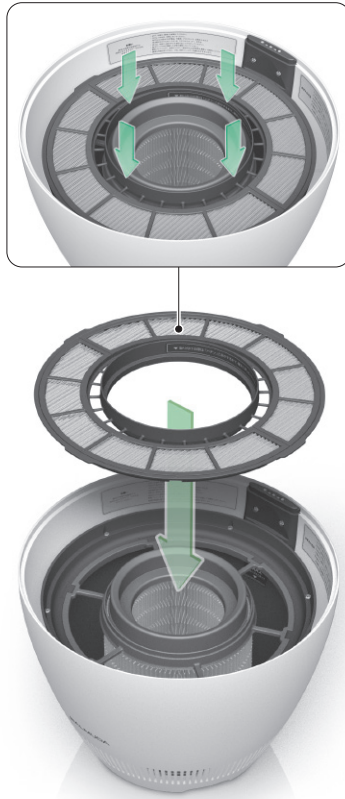

8 Set the Enzyme Prefilter.

! Hold the main unit upper body in the position shown.

*Do not hold this area, as your fingers may get caught.

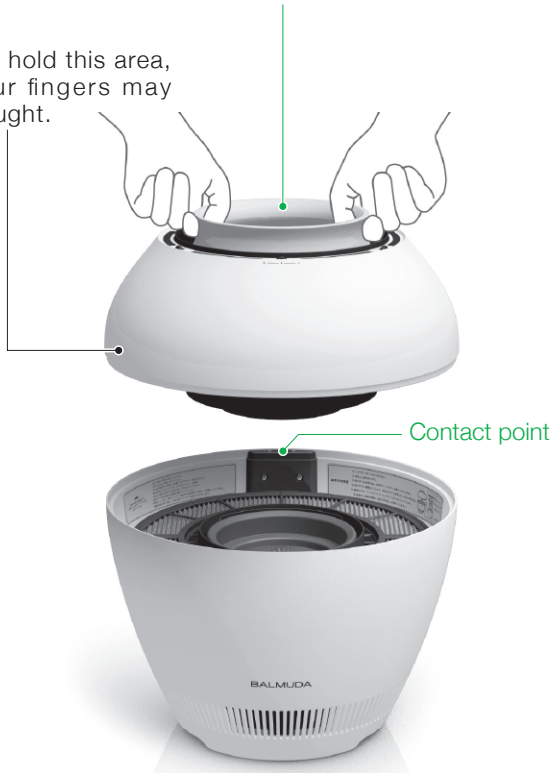

9 Set the main unit upper body.

Set the main unit upper body and lower body, aligning the contact points.

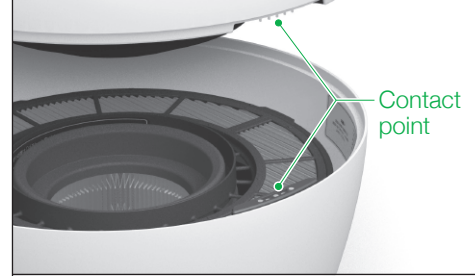

Place the upper body close to its final position and rotate from there.



When the contact points are aligned, the upper and lower body will fit together completely, with no gap.



! Take care not to get your fingers caught.



The Control Ring contains a magnet, allowing it to be set simply by placing it on the main unit.

10 Set the Control Ring.



Connect the AC adapter by inserting all the way in.

*The AC adapter makes a popping sound when it is correctly connected.

11 Insert the AC adapter into a wall outlet to complete preparation.

! Be sure to observe the following points when installing.



Do not use under a table or desk. This blocks the air outlet, preventing the humidified air from traveling throughout the room.



Do not install on an unstable surface such as thick-piled carpet. Doing so causes the unit to topple and the water to spill, causing electric shock or fire.



Install at a suitable distance from walls and furniture to achieve the intended performance of this product. Allow at least 120 cm of space above the air outlet when installing.

Installation

24h Timer button

The 24-hour Timer can be activated/deactivated directly by long pressing this button.

*For information on the 24h Timer button. **P.20**

Power button

Turns the power on and off.

*The child lock can be set or released by long pressing and the power button for approximately two seconds. **P.29**

Operating Section

Control Ring

Most operations, such as adjusting the air volume, setting the humidity selecting and activating menu's, are performed by rotating or clicking the Control Ring.

The power can also be turned on by clicking the Control Ring, and can be turned off by long pressing the Control Ring.

*The switch is located in the "+ — • — -" display area at the front.



Display

OEL display

The OEL display shows detailed operating information so that it can be viewed at a glance.

Air volume/water volume indicator

During normal operation, this indicates the air volume. The five air volume levels are indicated in green. This switches automatically to a water volume indicator when filling with water.

Display dimming

The display will become bright only while the unit is being operated.

If the unit is not operated for more than 1 minute, the indicators on the main unit automatically switch to low brightness. They are only displayed brightly while the unit is being operated.

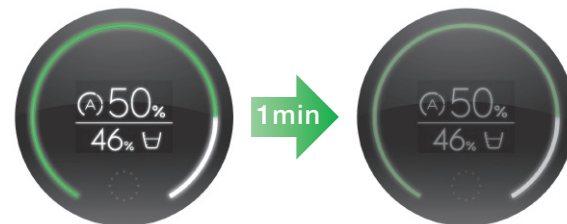

While the unit is being operated

When the unit is not being operated (dim)



Mode icon

The current Operating Mode is indicated by icons.

24h Timer icon

Displayed when the 24h Timer is set.

Current humidity

The current humidity is displayed.
*This may differ slightly from the actual humidity depending on the conditions of the room where the unit is being used.

Air volume indicator

This indicates the current air volume. The volume is displayed from 0 (no air output) to 5.

- The volume of air can be adjusted manually when operating in Manual Mode.
- When operating in Auto mode, this unit adjusts the air volume automatically.

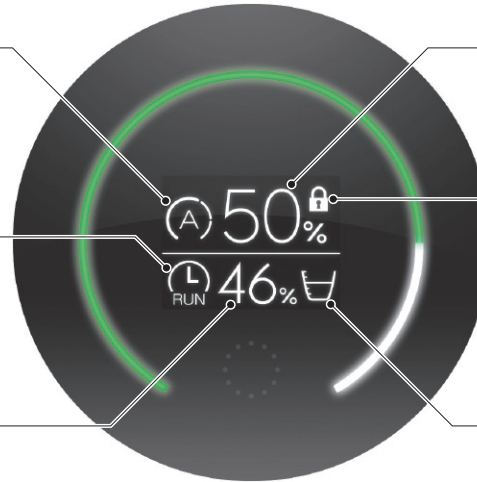

Standard screen

Humidity setting

The current humidity setting is displayed.

Child Lock icon

This is lit when the Child Lock function is activated by long pressing the Power Button for around two seconds.

Remaining water volume icon

The volume of water remaining in the Water Supply Bowl is displayed.



When the air volume is set to 0 (no air output)

During the Auto mode, when the room reaches a sufficient humidity, the air volume will automatically turn to 0 and the air output will stop. The indicator will turn completely white when the volume is 0.

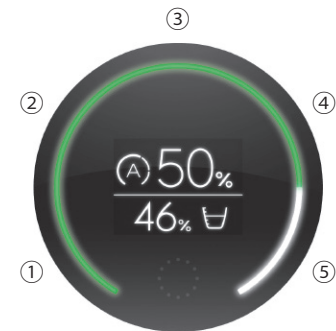

The green LEDs indicates the air volume levels

The image above shows the status when an air volume of 4 is indicated.

Operating Mode and 24h Timer



Auto mode (automatic operation)

Auto mode is an automatic operation mode that maintains a fixed humidity in the room. A humidity level is set manually and the unit automatically adjusts the air volume to reach this humidity. Five humidity levels can be set (40%, 45%, 50%, 55% or 60%) and the setting can be changed simply by rotating the Control Ring. The humidity is set at 50% when using this mode for the first time.

Humidity setting
Five levels can be set (40%, 45%, 50%, 55% or 60%).

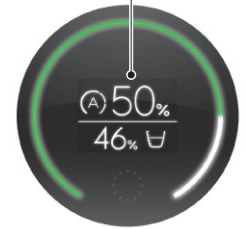

Standard screen in Auto mode



Manual Mode (setting the air volume manually)

Manual Mode is a mode in which the air volume is set manually. The air volume can be set as desired, regardless of the humidity in the room. Five volume levels can be set (1, 2, 3, 4 or 5) and the setting can be changed by rotating the Control Ring. The air volume is set at 1 when using this mode for the first time.

Air volume

Five levels can be set (1, 2, 3, 4 or 5).

Air volume meter

The five volume levels are indicated on a meter.

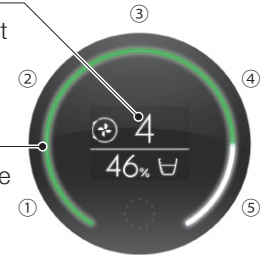

Standard screen in Manual Mode

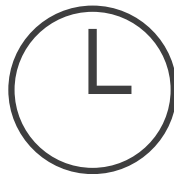

24h Timer (setting the unit to operate or stop each hour) **P.20**

Operation status (operating or stopped) can be set for each hour. The 24h Timer is active in both Auto mode and Manual Mode, modes can be switched while the timer is operating. Hourly operation statuses (operating or stopped) can be set for 24 hours, making it possible to operate the unit as desired by timer all day. This allows convenient use according to the patterns of your daily life.

Filling with Water

Pour water directly into the water supply hole using a kettle, etc.

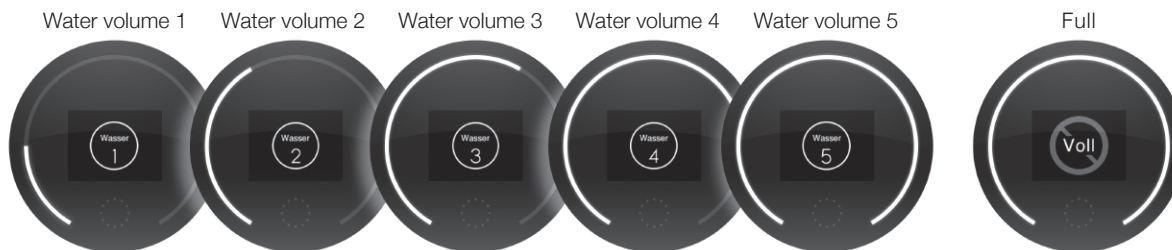

When you begin filling with water, the water volume sensor activates and the water volume will be indicated on the display.

Stop filling with water
The Water Supply Bowl is full at around 4.2 l.

Be careful of the following points when filling with water.

- Stop filling with water when "Full" is displayed. Otherwise, water may overflow from the Water Supply Bowl and wet the floor.
- Operation stops when the remaining water is low in any Operating Mode. Fill with water and resume operation.
- Use fresh, plain tap water. Using old water may result in bacteria breeding inside the unit.
- Do not use mineral water, alkaline ionized water, well water, or water purified by a water purifier. This may result in bacteria breeding inside the unit.
- Make sure that the AC adapter is connected to the wall outlet when filling with water, to ensure that the water volume in the Water Supply Bowl is detected.
- Be careful not to spill water on the outside or around the unit when filling with water. Doing so may result in water getting into the air intake, causing the unit to malfunction.

Take care to ensure that water does not enter the surrounding air outlet.



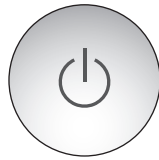

Turning the power on

Press the Power Button to turn the power on.

*The power can also be turned on or off using the Control Ring. **P.12**

Operating the Unit

Setting the volume/humidity

Rotate the Control Ring to set the volume or humidity.

- Set the air volume in Manual Mode
 - Set the humidity in Auto mode
- P.15**

Entering the menu screen

For detailed operations such as changing the modes, setting the 24h Timer and configuring settings, click the front of the Control Ring to enter the menu selection screen. **See next page**

Air volume/Humidity settings

Increase

Rotate

Air volume/Humidity settings

Decrease

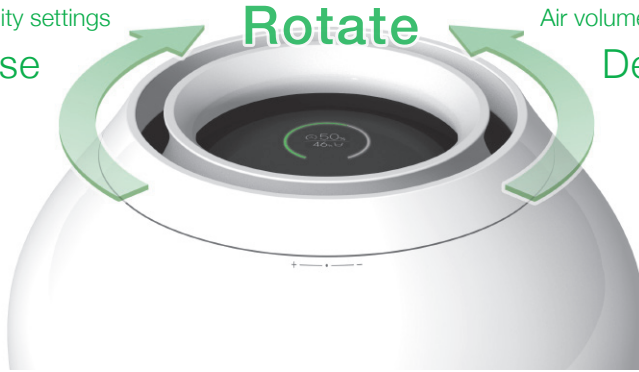

Press



Selecting a menu

Various functions for this unit can be selected from five menus: Auto, Manual, 24h Timer, Setting and Filter Cleaning Sign. Press the Control Ring while the "Operating" status is displayed to enter the menu selection screen. A menu can then be selected by rotating the click wheel and scrolling through the screen.

*Long press the Control Ring to return to the standard screen from the menu selection screen.



Menu selection screen

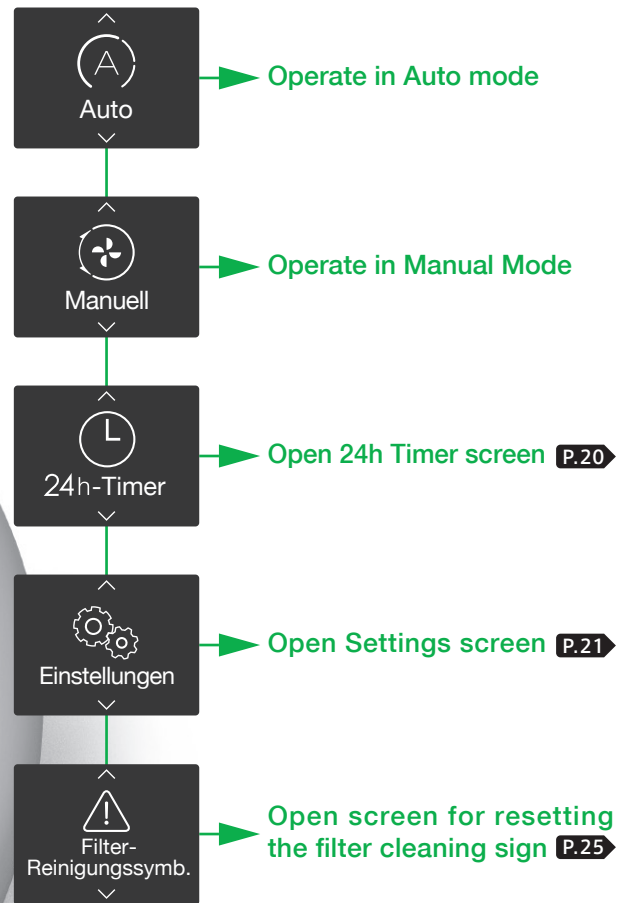

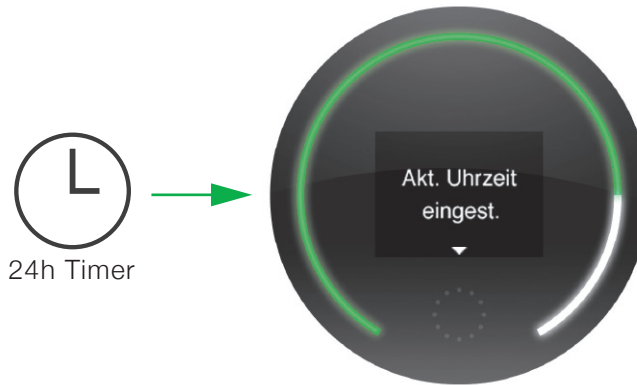

This unit equipped with a clock function.

The message on the left is displayed automatically the first time the 24h Timer mode is selected.
*The current time can also be set in Settings.

P.21 ➔

Current Time

**Set the time by following the steps below.
(The clock on this unit uses 24-hour time.)**

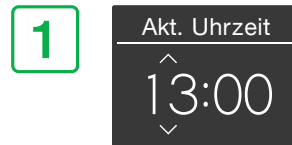

Set the hour using the Control Ring and then click to commit it.

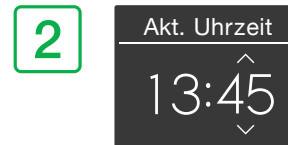

Set the minute using the Control Ring and then click to commit it.

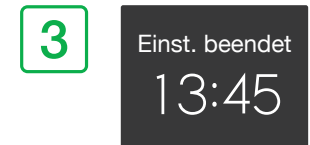

"Einst. beendet" is displayed and the setting of the current time is completed.



The clock needs to be reset if the plug is removed from the wall outlet for one week.

24h Timer Settings

Select "24h Timer" from the menu selection screen.



To set

An hourly schedule for starting and stopping operation needs to be set before using the 24h Timer.

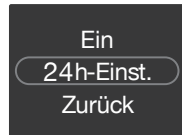

Click "24h-Einst.".



Set the timer.

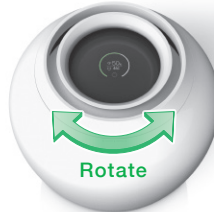

Rotate to scroll



- START
- START
- STOP



Click to set the unit to operate or stop

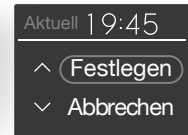

Click "OK".

Setting the unit to operate or stop each hour

Rotate the Control Ring to scroll through the screen and click to set this unit to operate or stop each hour.



"START" is displayed when set to operate.

The unit operates during these hours.



"STOP" is displayed when set to stop.

The unit stops operating during these hours.

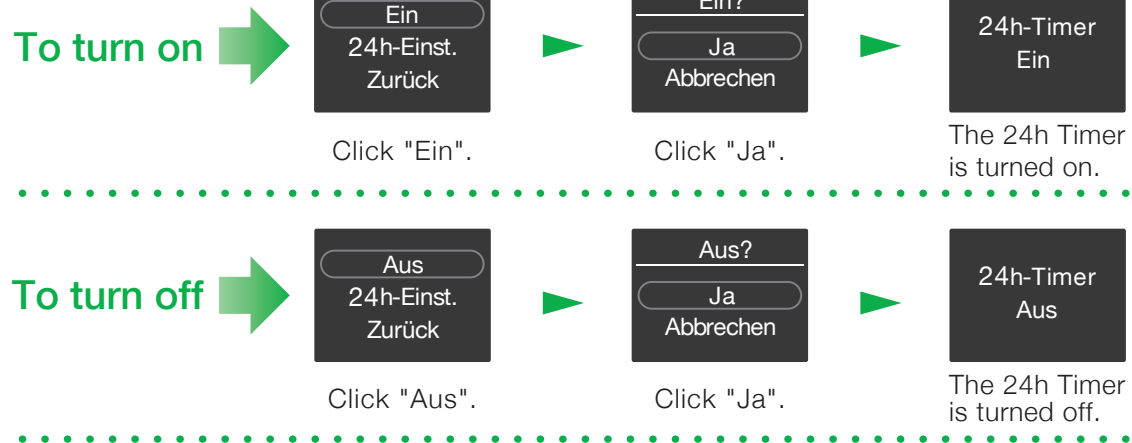



Rotate to "Einstellungen" in the menu selection screen and then click to select it.



The output indicators flash in white and the air volume switches to 0 when the Settings screen is entered.

Settings (Unit Settings)

Various settings can be configured as desired, such as making the indicators dimmer or lowering the volume of operating sounds.

Various settings can be configured for the main unit as desired.

Display-Hell.

The brightness of the indicators and the OEL display can be adjusted.

Lautstärke

The volume of operating sounds can be adjusted.

Akt. Uhrzeit

The current time can be set.

Geräteeinst.
Zurück

Einst. zurücks.

Resets the settings to the factory default.

Firmware-
Informationen

Information on the firmware of this unit can be set.

Zurück

Returns to the previous screen.

Details on main unit settings

Display brightness Adjust the brightness of the indicators and the OEL display if they are too bright or are too dim to see properly. The brightness can be selected from three levels: High, Medium and Low. The factory default is Medium.

Operating Sound The volume of operating sounds can be adjusted. The volume can be selected from three levels: High, Medium and Low. The factory default is Medium.

Current Time This unit is equipped with a clock function. The time needs to be set in order to use the 24h Timer. If the current time is not correct, set it again in "Einstellungen" > "Geräteeinst." > "Akt. Uhrzeit".

Reset Settings Reset all settings you have configured for "24h-Timer-Einstellung", "Geräteeinst." and "Einstellen der Luftfeuchtigkeit im automatischen Modus" to the factory default.

Maintenance

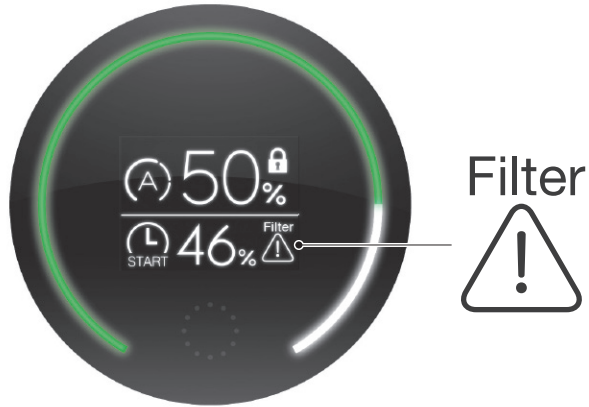

Filter Cleaning Sign

The filter cleaning sign is displayed after around two weeks of use. Be sure to clean the filter when this is displayed. Continuing to use the unit without cleaning it may cause scale to form and become too hard to remove, or cause mold or bacteria to breed. Clean the filter regularly to prevent odors and a decrease in the humidifying capacity.

! Remove the AC adapter from the wall outlet first.

1 Disassemble the main unit.



Remove the Control Ring.



Remove the main unit upper body.



Be sure to place with the display facing upward. Placing the unit upside down may cause water to enter the display and damage the unit.

Place it on a towel, etc. so that the floor does not get wet.

4 Remove the Humidifying Filter Holder.

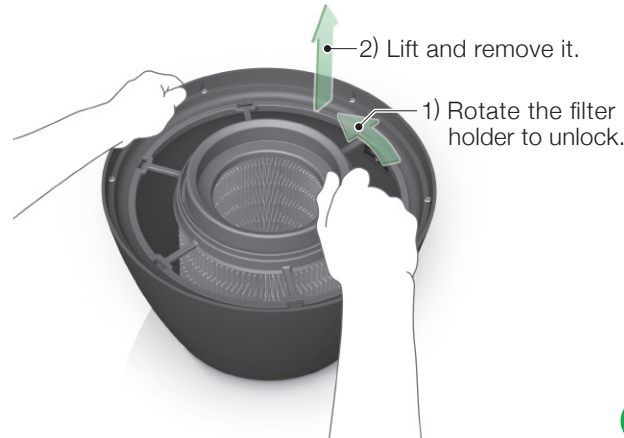

5 Rinse the Humidifying Filter under running water.



! Take care not to deform the filter.

2 Remove the Enzyme Prefilter and clean it with a vacuum cleaner.



Remove the Enzyme Prefilter.

Remove dust with a vacuum cleaner.

Do not wash the Enzyme Prefilter.

3 Remove the Water Supply Bowl, holding it in the position shown.

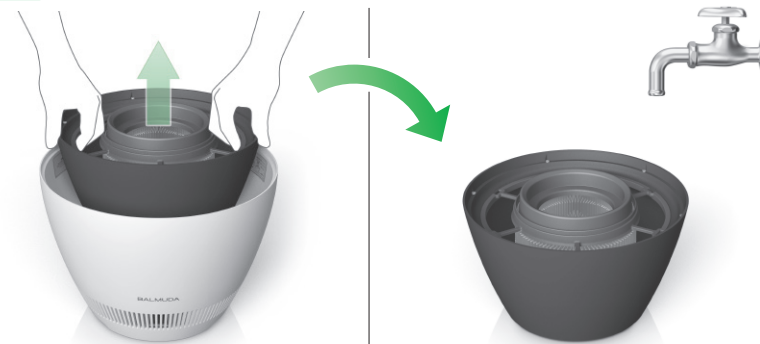

Hold the Water Supply Bowl in the position shown and lift it out.

Move it to the bathroom, etc. for washing.

6 Wash the silver ion cartridge.



7 Wash the Water Supply Bowl.



8 Wipe away any water that remains in the Water Supply Bowl.

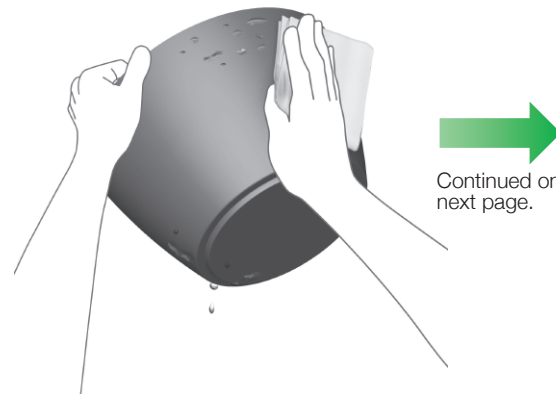

Continued on next page.

9 Assemble. *See P.7-P.10 for assembly instructions.

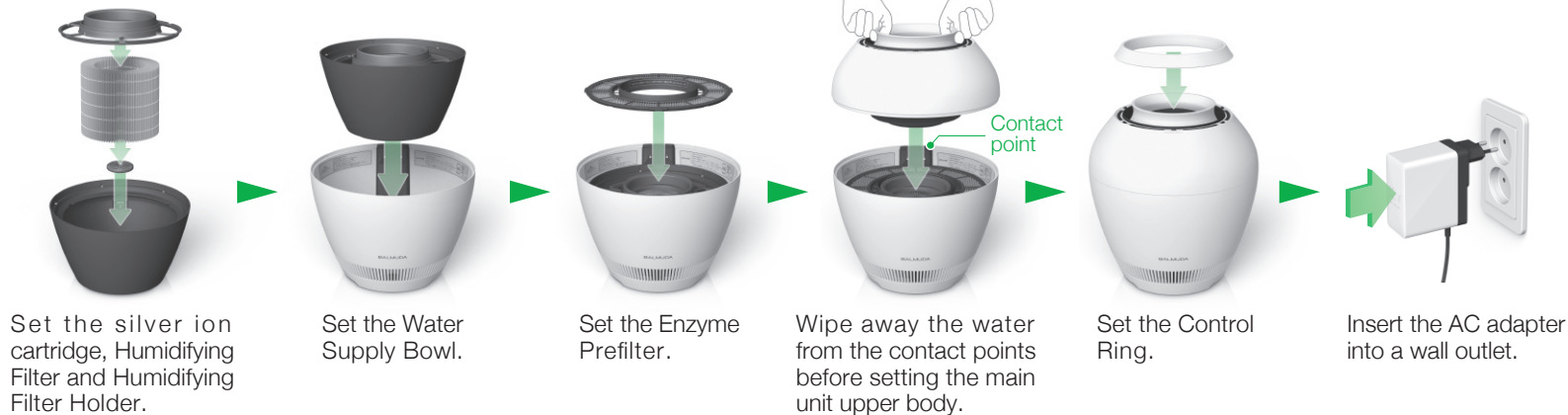

10 Reset the filter cleaning sign.

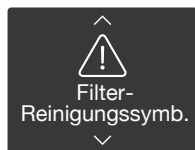

Select and click "Filter-Reinigungssymb." in the menu selection screen.



Click to proceed to the next screen.

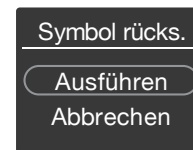

Click "Ausführen".

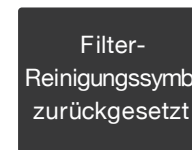

This completes resetting.

Storage

How to store

If you will not use the unit for a long time, clean it according to the instructions in "Maintenance" and thoroughly dry the parts that have been washed. After this, store the unit in a place with minimal dirt or dust. Avoid areas with high temperatures, high humidity or direct sunlight.

Cleaning the Humidifying Filter

Cleaning with citric acid or baking soda

It is recommended to clean the Humidifying Filter by soaking it approximately once every two weeks to one month.

Clean with baking soda if the output air has an odor, or clean with citric acid to remove scale (mainly slime) or calcium salt (white solid) on the Humidifying Filter. Dissolve baking soda or citric acid in cold or lukewarm water deep enough to cover the filter and soak the filter for around 60 minutes. Baking soda and citric acid can be purchased from drugstores, home centers, etc.



If the output air has an odor

Approx. 60 g of baking soda per ℓ of water

Thoroughly dissolve the baking soda in the water.



To remove scale or calcium salt

Approx. 6.5 g of citric acid per ℓ of water

Thoroughly dissolve the citric acid in the water.

Clean by soaking for
approx. 60 min



*Do not soak the filter in the Water Supply Bowl. Soak it in another container, such as a bucket.



Rinse thoroughly with fresh water 2-3 times after soaking.

If baking soda or citric acid remains in the filter, this may cause an odor or damage the unit.



Do not soak or wash the Enzyme Prefilter.



Do not clean the Humidifying Filter with hot water.

Replacing the Filter

The standard replacement time of the filter is six months.

Replacement may be required sooner depending on how the unit is used or the usage environment.

- The life may be shorter depending on the hardness of your tap water.
- Depending on the usage conditions, replacement may be required, due to dirt buildup or deformation, after several weeks or several months.
- A charge applies for new filters even during the warranty period, as they are a consumable item.
- Please dispose of your old filter in accordance with your local area's waste disposal system and regulations.

Main materials of the Enzyme Prefilter ····· Polypropylene, polyester, rayon, etc.

Main materials of the Humidifying Filter ····· Polypropylene, polyester, polyolefin

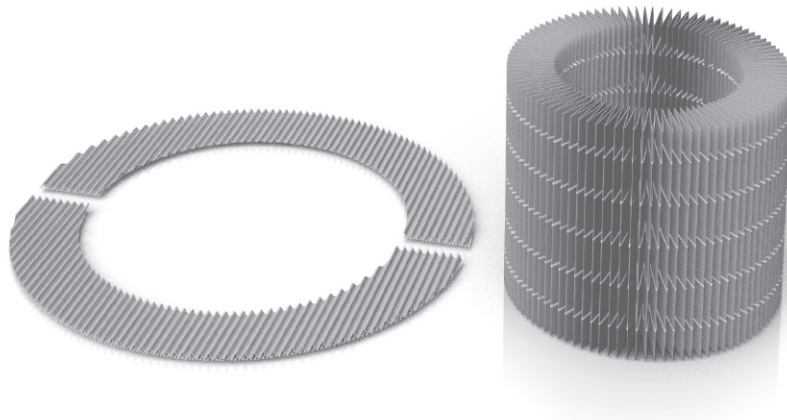

Besuchen Sie zum Erwerb von Ersatzfiltern die unten stehende Webseite.

**■ BALMUDA Europe Service Center
(nur an Wochen- und Geschäftstagen, 9:00-16:30)**

040-897 25 35 15

(* Anruf gebührenpflichtig)

How to replace the Enzyme Prefilter

Follow the steps below to replace the Enzyme Prefilter with a new one. (filter replacement sold separately).

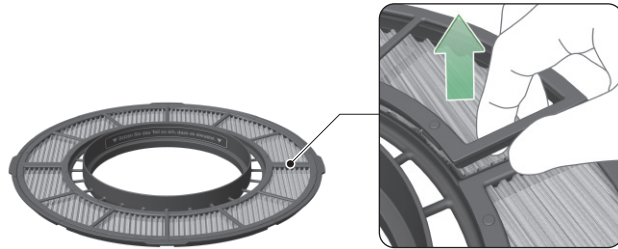

- 1** Remove the cover by grasping the position indicated in the picture and lifting.

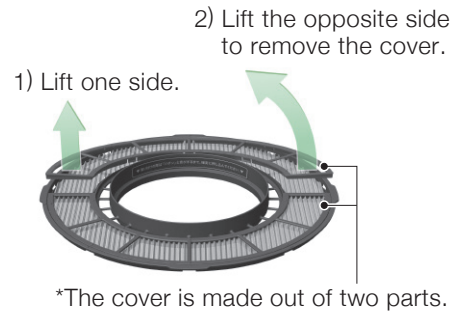

- 2** Remove the covers one by one as in the procedure shown by the picture.

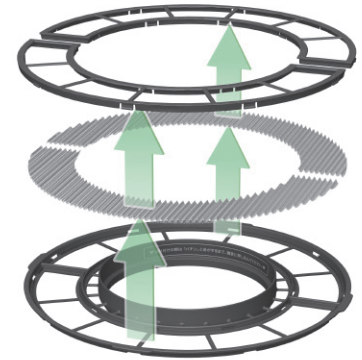

- 3** Remove the two covers to remove the filter.

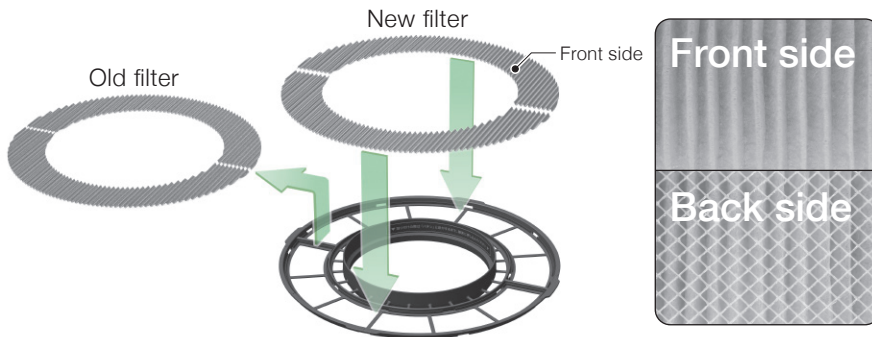

- 4** Replace the old filter with a new one. When replacing the old filter, make sure to set the new one with its front side facing upward. Take care not to confuse the front side and back side.

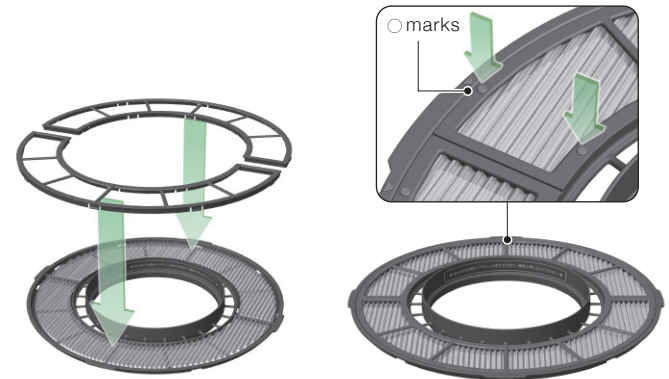

- 5** Attach the cover. When attaching the cover, make sure that all the 20 positions with a \bigcirc mark are firmly inserted. They will make a click sound when correctly inserted.

Error Detection Function and Safety Functions

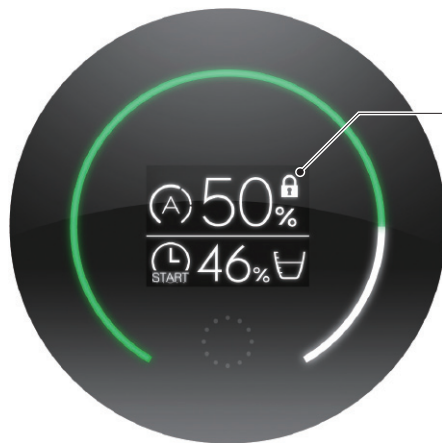

Child Lock

This can be set or released by pressing and holding the Power Button for around two seconds to prevent young children from operating this unit by mistake.

*No operations except releasing the Child Lock are possible when the Child Lock is set. The Child Lock can be set even when the unit is on standby.



Main Unit Operation Error Detection

The unit stops operating if an abnormality is detected inside the unit, such as motor rotation or sensor.



Overfilling

The unit stops operating if it is filled with more than the maximum volume of water.

*Take out the Water Supply Bowl and remove water until the water is below the "full" line.

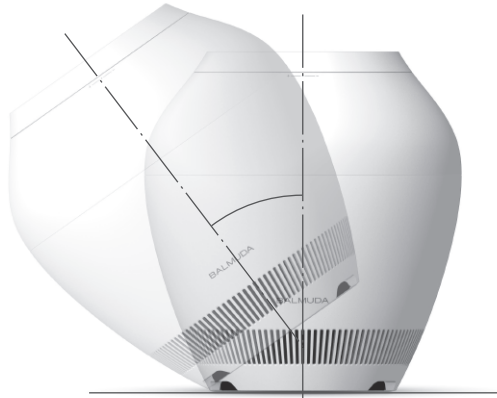

Tilt Alert

The unit cannot operate if it is tilting or toppled.



Impact/vibration detection

The unit stops operating if it receives more than a prescribed level of vibration due to causes such as earthquakes or impact.



Water Supply Bowl Error

The unit cannot operate when the Water Supply Bowl is not set.

*An error may also occur if the Water Supply Bowl is not set correctly.

Troubleshooting **The unit cannot be operated or suddenly stops operating.**

Operation of this unit may be automatically stopped by the error detection function or the safety function (see previous page).

It may not be possible to resume operation depending on the type of error. If you encounter an issue, inspect the unit first according to the checklist below.

✓ **Has the unit received significant impact or vibration?**

Operation may have been stopped by the impact and vibration detection function.

Solution ▶ Resume operation in conditions with no vibration or impact.

✓ **Is the unit tilting?**

The unit cannot operate if it is tilting or lying down.

Solution ▶ Install the unit on a stable, flat surface and resume operation.

✓ **Is there a gap between the main unit upper body and lower body?**

Operation is not possible if there is a gap, as the contact points are not aligned.

Solution ▶ Rotate the main unit upper body and align the contact points.

✓ **Is the unit overfilled with water or is the water low?**

Operation stops if the unit is overfilled with water or if the water is low.

Solution ▶ If the unit is overfilled with water, take out the Water Supply Bowl and remove water until the water level is below the "full" line. If the water is low, add more water.



Error codes

Error codes are displayed when an error is detected. Providing the displayed error code when contacting the BALMUDA Europe Service Center may make it easier for representatives to assist you in solving the problem.

If the cause cannot be determined from the above checklist, contact the BALMUDA Europe Service Center.

BALMUDA Europe Service Center
(nur an Wochen- und Geschäftstagen, 9:00-16:30)

040-897 25 35 15

AC adapter

BALMUDA Multi-plug Adapter

The BALMUDA Multi-plug adapter can be attached to point 4 different directions so that the AC adapter can be inserted accordingly to the wall outlet.

Upward



Right



Downward



Left



Remove

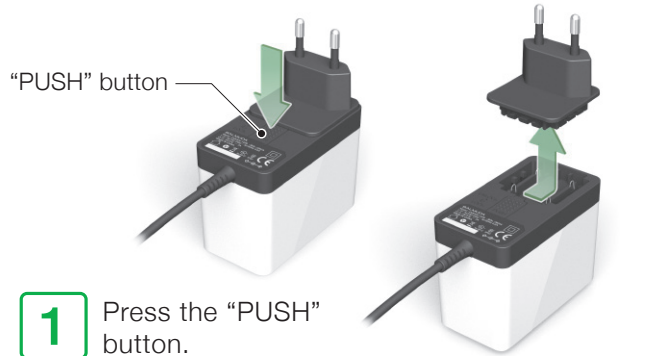

1 Press the "PUSH" button.

2 Slide the plug unit out.

Attach

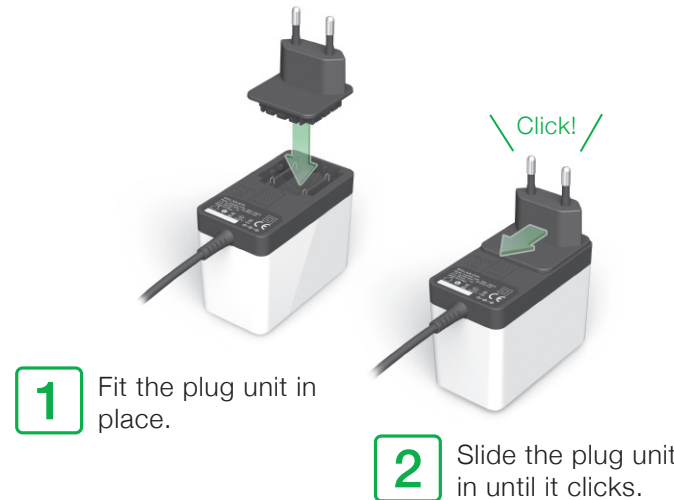

1 Fit the plug unit in place.

2 Slide the plug unit in until it clicks.



Safety Precautions

Be sure to observe these precautions.

Read the Safety Precautions thoroughly before using this product to ensure correct use. The safety precautions in this manual are included to ensure safe and correct use of this product and to prevent danger or damage to the user or other parties.

Explanation of indications



Warning Indicates an action that may result in death or severe injury.



Caution Indicates an action that may result in minor injury or damage to the user's home or property.

Explanation of symbols



Prohibited Indicates a prohibited action that must not be performed.



Instruction Indicates an instruction that must be followed.

Warning

- Do not use for purposes other than those written on this instruction manual.
- Do not allow children or persons unable to understand the instructions on the manual operate the product.
- To avoid electrocution risks, do not soak the product, cord or plug in water or any other liquid.
- Do not disassemble except for maintenance purposes.
Fire, electrocution or serious injury may result. For repairs, please consult your dealer or BALMUDA Europe Service Center (P.45).
- Insert the power plug completely.
- Do not use if there is damage to the cord or power plug, or the plug connection is loose.
- Unplug when not in use.
- Do not damage, modify, bend, pull, twist, or bundle the cord. Do not place heavy things on top, or pinch the cord.
- Keep the cord away from sharp edges of tables, counters and hot surfaces.
- Use general household power outlet for the AC adapter.
- To unplug, always hold the AC adapter to remove the plug, and do not pull the cord. Remove any dust from the plug on a regular basis.
- To avoid fire or electrocution risks, do not use together with a solid state fan speed control device.
- Do not insert wires, clips, etc. into the air vents or air outlet. Doing so may cause electric shock.
- Make sure the BALMUDA Multi Plug AC Adapter is firmly secured when in use.
- Always unplug the product before maintenance. Do not plug/unplug with a wet hand.
- If the unit falls or topples, do not continue to use. Remove the AC adapter from the wall outlet and request inspection.

Contact the BALMUDA Europe Service Center (P.45) to request inspection.

Warning

- If using in a room with dogs, cats and other indoor pets take care to ensure that they do not damage the unit or power cord. Doing so results in fire or damages the product.
- This unit is for use in Germany, Austria and Switzerland only. Do not use in other countries.
- Do not use AC adapters other than that specified. Doing so may damage the product or cause fire.
- Do not use a power supply other than AC100-240 V. Doing so may damage the product or cause fire.
- Be sure to take out the Water Supply Bowl before draining the water. Draining the water while the Water Supply Bowl is in the main unit may cause water to spill inside the unit, damaging the product or causing electric shock.
- Be sure to remove the water from the Water Supply Bowl before moving the unit. Moving the unit with water still in the Water Supply Bowl may cause it to spill, damaging the product or causing electric shock.
- Do not install on an unstable surface such as thick-piled carpet. Doing so causes the unit to topple and the water to spill, causing electric shock or fire.
- Do not use on or near household appliances such as a TV or heater. If the unit topples and spills water it may cause fire or electric shock.
- Do not climb or sit on the product. Doing so may cause the unit to topple, causing injury.
- Take care to ensure that children do not play with the Control Ring, Water Supply Bowl Plate, etc. Doing so may cause unexpected injury.

Cautions

- **Do not use the product in the following places since it may cause electrocution or fire.**
 - a. Near gas stoves or near open flames
 - b. In/around flammable gases
 - c. In/around water or rain
- **Do not transport the assembled product. Place the product in a box before transportation.** Otherwise, the product or parts may get damaged.
- **Do not use sprays or liquids on the product.** Inflammable sprays may cause fire or explosion. Other sprays may damage the plastic or paint.
- **Do not let children use by themselves. Keep out of reach of small children.** Children should use only under adult supervision.
- **Store in a dry place out of reach of children.**
- **Take care not to block the air vents or air outlet with curtains, etc. Doing so results in malfunction or damages the product.**
- **Keep long hair and loose clothing away from the moving parts.**
- **For indoor use only.**
- **This appliance can be used by children aged from 8 years and above and persons with reduced physical, sensory or mental capabilities or lack of experience and knowledge if they have been given supervision or instruction concerning use of the appliance in a safe way and understand the hazards involved.**
- **Do not drink the water from the Water Supply Bowl or allow others to drink it. This is a health hazard.**

Cautions

- Keep the inside of the unit clean with regular cleaning. Replace the water in the tank with new plain tap water every day.
- Install on a flat surface. Do not install on thick-piled carpet or on an uneven floor.
- Do not clean this unit with chlorine-based or acidic detergents. This may create toxic gases, which are a health hazard.
- Be sure to set the Enzyme Prefilter and Humidifying Filter on this unit. The intended performance is not achieved if the unit is operated without setting these. This may also damage the product.
- Only use plain tap water suitable for drinking. Do not use the following types of liquid. Doing so damages the product. Hot water over 40°C as well as water that contains chemicals, aromatics, well water, water that contains aroma oil, water that contains detergent, water purified by a water purifier, alkaline ionized water or mineral water.
- Remove the water and be sure to remove the plug from the wall outlet when the unit will not be used for a period of time. Otherwise, electric shock, short-circuiting or fire may occur due to insulation deterioration.
- Do not use under a table or desk. This stops the humidified air from traveling throughout the room.
- If an abnormality occurs, stop using the unit and request an inspection.
Contact your dealer or the BALMUDA Europe Service Center (P.45) to request an inspection.
- Do not lift the upper body while the unit is operating. Doing so damages the product.
- Do not disassemble the silver ion cartridge. Take care to ensure that contents do not enter mouth, etc.
- Do not place other objects on this unit. This blocks the air outlet, preventing the intended performance.
- Take care to ensure that water does not enter the air outlet when filling. Doing so may damage the product.

Specifications



Main unit

Product name	Rain				
Model	ERN-1000SD				
Operating modes	Air Volume1	Air Volume2	Air Volume3	Air Volume4	Air Volume5
Maximum humidification performance*1	150 ml/h	250 ml/h	400 ml/h	500 ml/h	600 ml/h
Power consumption	2 W~23 W				
Operating noise	6 dB~42 dB				
Recommended room size	Approx. 28 m ²				
Capacity of Water Supply Bowl	4.2 ℓ				
Dimensions of main unit	(W)350mm × (D)350mm × (H)374mm				
Weight of main unit	Approx. 5.7kg (approx. 10kg when full)				
Timer	24-hour Timer function				
Usage environment	For household use, for use in Germany, Austria and Switzerland only, for indoor use only				
Safety equipment	Impact/vibration detection Vibration recognition threshold: Vibration equivalent to a strong earthquake				
	Tottle alert Tilt recognition threshold: Approx.15°				
	Error notification function Main unit operation error detection/Overfill/Water Supply Bowl error				

AC adapter

Rated input voltage	AC 100-240 V
Rated input capacity	79-93 VA
Rated frequency	50/60 Hz
Rated output voltage	DC 12 V
Rated secondary current	3 A
Cord length	Approx. 1.8 m

*1 The humidification performance refers to the maximum performance in a room temperature of 20°C and humidity of 30%.

Warranty and AfterService

For inquiries on repairs, usage, or maintenance, please call the BALMUDA Europe Service Center (P.45), or contact your dealer.

- 1) Please receive the warranty card from your dealer with the purchase date and the dealer name filled in.
- 2) The warranty is valid for 2 years from the date of purchase. For repairs during the warranty period, please contact the BALMUDA Europe Service Center (P.45) or your dealer.

The repairs will be carried out according to the warranty.

- 3) Contact the BALMUDA Europe Service Center (P.45) or your dealer for out-of-warranty repairs. You can request for a repair with charge, if it enables the product to function properly.
- 4) Never attempt to repair or modify the product by yourself.

Handling of Personal Information

- 1) BALMUDA Inc. (hereinafter “BALMUDA”) may use personal information for customer service and repairs, and may keep a record of the inquiries.
- 2) BALMUDA will not disclose personal information to third parties, except in the following cases:
 - a. When repairs or confirmation of repairs are entrusted to third parties.
 - b. In cases pursuant to the provisions of laws and regulations.
- 3) For inquiries on personal information, please contact the BALMUDA Europe Service Center (P.45).

Correct Disposal of this Product

This marking indicates that this product should not be disposed with other household wastes throughout the EU. To prevent possible harm to the environment or human health from uncontrolled waste disposal, recycle it responsibly to promote the sustainable reuse of material resources. To return your used device, please use the return and collection systems or contact the retailer where the product was purchased. They can take this product for environmental safe recycling.



FAQ

Symptom	Check Points	Solution	Page
Power does not switch on.	● Is the AC adapter inserted into the wall outlet correctly?	▶ Insert the AC adapter securely into the wall outlet.	◀ P.10
	● Is the AC adapter plug connected to the unit correctly?	▶ Insert the AC adapter plug securely into the unit.	◀ P.8
	● Is the Child Lock set?	▶ Release the Child Lock.	◀ P.29
	● Has the error detection function and safety function activated?	▶ Check the unit according to "Error Detection Function and Safety Functions" on P.29 of this manual.	◀ P.29 ◀ P.30
	● Has the circuit breaker in the house tripped?	▶ Check the house circuit breakers.	
	● Does the Water Supply Bowl contain any water?	▶ The unit cannot operate when the Water Supply Bowl is empty. Fill with water from a kettle, etc.	◀ P.16
	● Has the Water Supply Bowl been filled with water over the "full" line?	▶ The unit cannot operate when the Water Supply Bowl is filled with water over the "full" line. Take out the Water Supply Bowl and remove water until the water is below the "full" line.	◀ P.29 ◀ P.36
	● Are the Water Supply Bowl and Water Supply Bowl Plate set correctly?	▶ Set the Water Supply Bowl and Water Supply Bowl Plate correctly.	◀ P.8
	● Is the Humidifying Filter locked securely?	▶ Lock the Humidifying Filter firmly with the Humidifying Filter Holder.	◀ P.7 ◀ P.8

Symptom	Check Points	Solution	Page
Power does not switch on.	● Is there a gap between the upper body and lower body of the main unit?	▶ The unit cannot operate when the upper body and lower body of the main unit are not set correctly, as the contact points are not aligned. Rotate the upper body to the correct position and align the contact points.	P.9
Air volume has changed even though I didn't touch the controls.	● Is the unit operating in Auto mode?	▶ When operating in Auto mode, the air volume is automatically adjusted to keep the humidity in the room at the set humidity.	P.15
Air is not emitted from the unit even though the power is on.	● Has the 24h Timer operated?	▶ When the 24h Timer is active, air output is stopped during the time period for when "STOP" is selected in the 24h Timer setting. Check the status on the OEL display.	P.20
	● Is the humidity setting set to a low value in auto mode operation?	▶ Rotate the Control Ring in the "+" direction to increase the humidity setting.	P.17
	● Is "Setting" selected in the menu?	▶ Air output is temporarily stopped when "Setting" is selected. The unit will return to its previous mode once setting is completed.	
	● Is the unit being filled with water at the particular moment?	▶ Air output is temporarily stopped while the unit is being filled with water. The unit will return to its previous mode once the water is supplied.	
The humidity displayed on this unit is different to the humidity of the room.	● Is the hygrometer placed far away from this unit?	▶ Factors such as the installation location of the unit, height of the unit and presence of an air conditioner cause differences in the humidity display. Use the current humidity display as a guide.	

FAQ

Symptom	Check Points	Solution	Page
Air volume is weak.	● Is the humidity setting set to a low value in auto mode operation?	▶ Rotate the Control Ring in the “+” direction to increase the humidity setting.	◀ P.17
	● Is the air volume set to a low value in manual mode operation?	▶ Rotate the Control Ring in the “+” direction to increase the air volume.	◀ P.17
	● Does the filter need cleaning?	▶ Clean the filter.	◀ P.23
	● Are the air vent holes blocked by something such as a curtain or carpet?	▶ Check the installation environment of the unit.	◀ P.11 ◀ P.35 ◀ P.37
Cannot switch the operating mode.	● Is the Child Lock set?	▶ Release the Child Lock.	◀ P.29
The air volume indicator is flashing white and the unit has stopped operating.	● Has the error detection function operated?	▶ When an error is detected, the unit will automatically stop and the output indicator will flash in white. Disconnect and reconnect the AC adapter from the wall socket to clear the error detection function and restart. If for any reason normal operation does not resume, contact the BALMUDA Support Center (P.48).	◀ P.29
Filter cleaning indicator is displayed.	● Has the unit been left for a long time without being cleaned?	▶ Clean the filter and then reset the filter cleaning sign. See "Maintenance" on P.23 for details on cleaning.	◀ P.23
Indicator is dark.	● Is the "Display Brightness" setting of the main unit set to a dark setting?	▶ Check the "Display Brightness" settings of the main unit.	◀ P.21

Symptom	Check Points	Solution	Page
Indicator is dark.	● Has more than 1 minute elapsed without operating the unit?	▶ If the unit is not operated for more than 1 minute, the indicators on the main unit switch to low brightness.	P.13
Operating sound is quiet.	● Is the "Operating Sound" setting of the main unit set to a low setting?	▶ Check the "Operating Sound" settings of the main unit.	P.21
Humidity does not increase.	● Is the room where you are using this unit larger than the recommended room size?	▶ Be sure to use this unit in a room that is within the recommended room size range.	P.39
	● Is there an open window or door?	▶ Close all windows and doors when using this unit.	
Unit emits an odor.	● Has the unit been left for a long time without being cleaned?	▶ Clean the filter. See "Maintenance" on P.23 for details on cleaning.	P.23
The 24h Timer does not function correctly when set.	● Is the current time correct?	▶ This unit is equipped with a clock function. Set the clock to the correct time using the setting mode. The clock time is reset if the AC adapter remains disconnected from the power socket for approximately 1 week. Set the clock again.	P.21
I cannot see steam or vapor emitting from the unit.	● This is not a fault.	▶ This unit is a evaporative humidifier that uses a humidifying filter to add moisture to the air. It does not emit steam or vapor.	
Air emitted from the unit is cold.	● This is not a fault.	▶ The emitted air may be cooler than the surroundings because heat is lost from the water when it is vaporized.	

Inquiries

Kundenbetreuung

(für Anfragen zu Gebrauch, Wartung, Reparatur)

■ **BALMUDA Europe Service Center**

(nur an Wochen- und Geschäftstagen, 9:00-16:30)

040-897 25 35 15

(* Anruf gebührenpflichtig)

■ **Online-Anfragen**

Bitte starten Sie einen Suchvorgang mit dem Schlüsselwort „BALMUDA“ oder besuchen Sie uns bei <http://www.balmuda.com/support/>.

[Bitte prüfen Sie vor Ihrer Anfrage das Produktmodell (auf der beiliegenden Garantie)]

BALMUDA